

September 15, 1925
15 Cents a Copy

RADIO PROGRESS

Reg. U. S. Pat. Off.

*"Always Abreast
of the Times"*

IN THIS ISSUE

How Your Grid Leak is Made

By HORACE V. S. TAYLOR

How the Navy Cut Out Static
Broadcasting from the Polar Snows
What's New at New York Radio Show
Some Tests on Signal Strength
Give That Smart Look to Your Panel

YOU WILL UNDERSTAND THIS
MAGAZINE --- AND WILL LIKE IT

A New England Publication

At Last! At An Unheard of Price!

A SURE FIRE

SUPER-HETERODYNE KIT

A
Superadio
Product

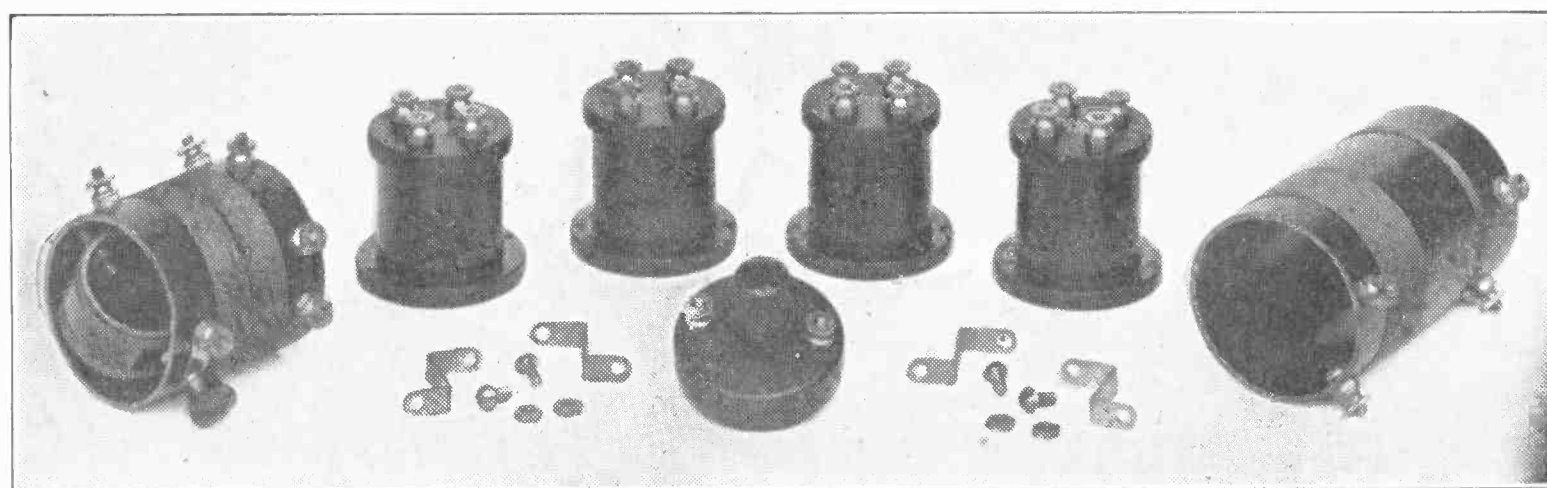

A
Superadio
Product

SUPERADIO KIT, \$17.50 SUPERHETERODYNE

MATCHED TRANSFORMERS—TUNED INPUT

EASY TO BUILD

EASY TO OPERATE

UNSURPASSED DISTANCE VOLUME AND SELECTIVITY

WONDERFUL TONE

Kit Consists of:

- 1 Antenna Coupler
- 1 Oscillator Coupler
- 1 Special Variable Condenser

- 1 Tuned Input Transformer
- 3 Matched Intermediate Transformers
- Hardware for Mounting Couplers

Booklet, With Diagrams and Full Layouts
and Information

Manufactured by

DE WITT-LAFRANCE CO., Inc.

54 Washburn Avenue

Cambridge, Mass.

Sales Representatives:

Martin, Hartley and Foss Co.

99 Bedford Street, Boston, Mass.

NATIONAL

**VELVET CONDENSERS
VERNIER AND DIALS**

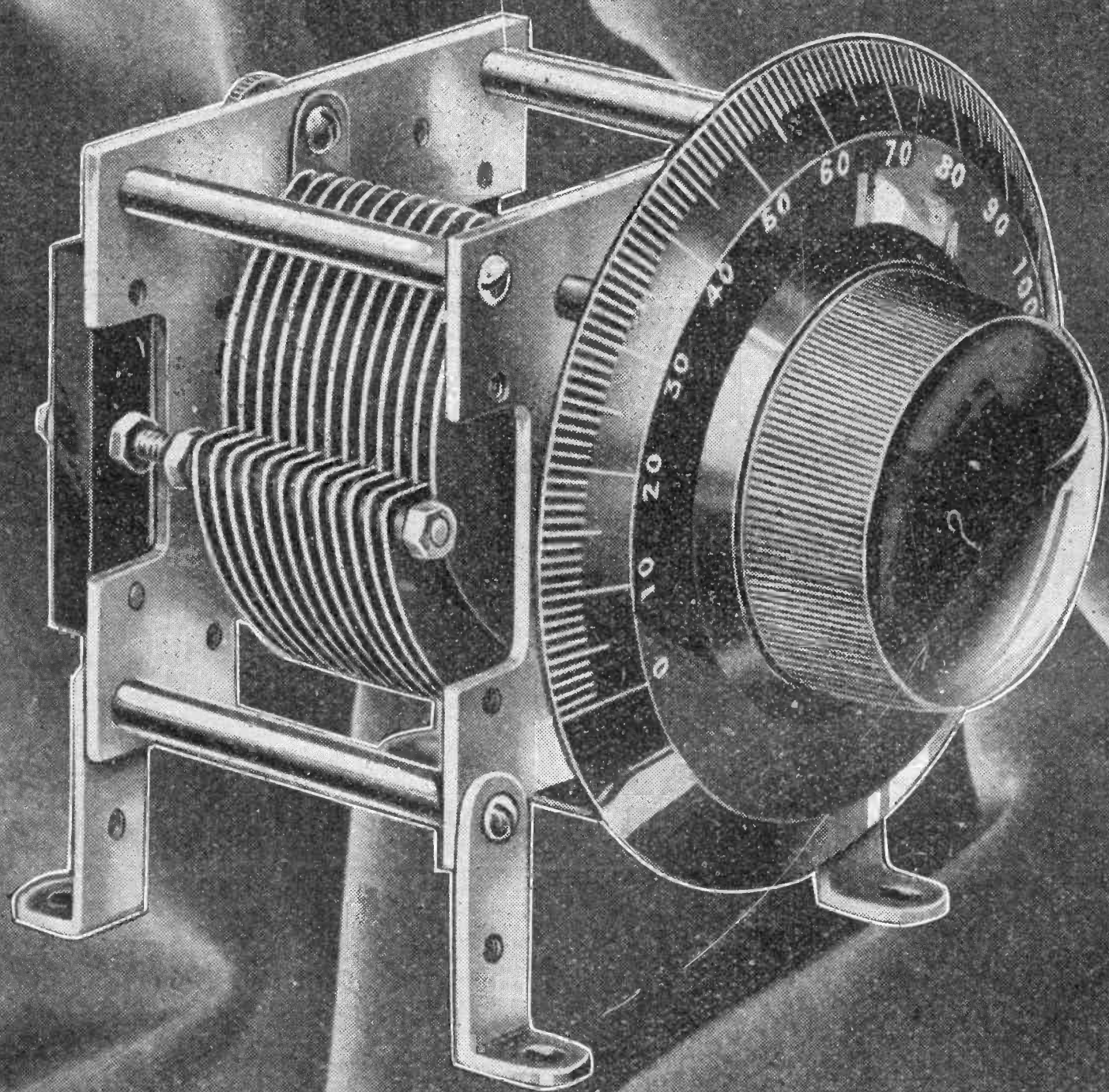

Made by the NATIONAL COMPANY, INC.

Exclusive Manufacturers of

The NATIONAL

Browning-Drake TRANSFORMER

Write for Bulletin 105 R. E.

NATIONAL COMPANY, INC., 110 Brookline St., Cambridge, Mass.



The Marvelous 5-Tube Radio Frequency Set

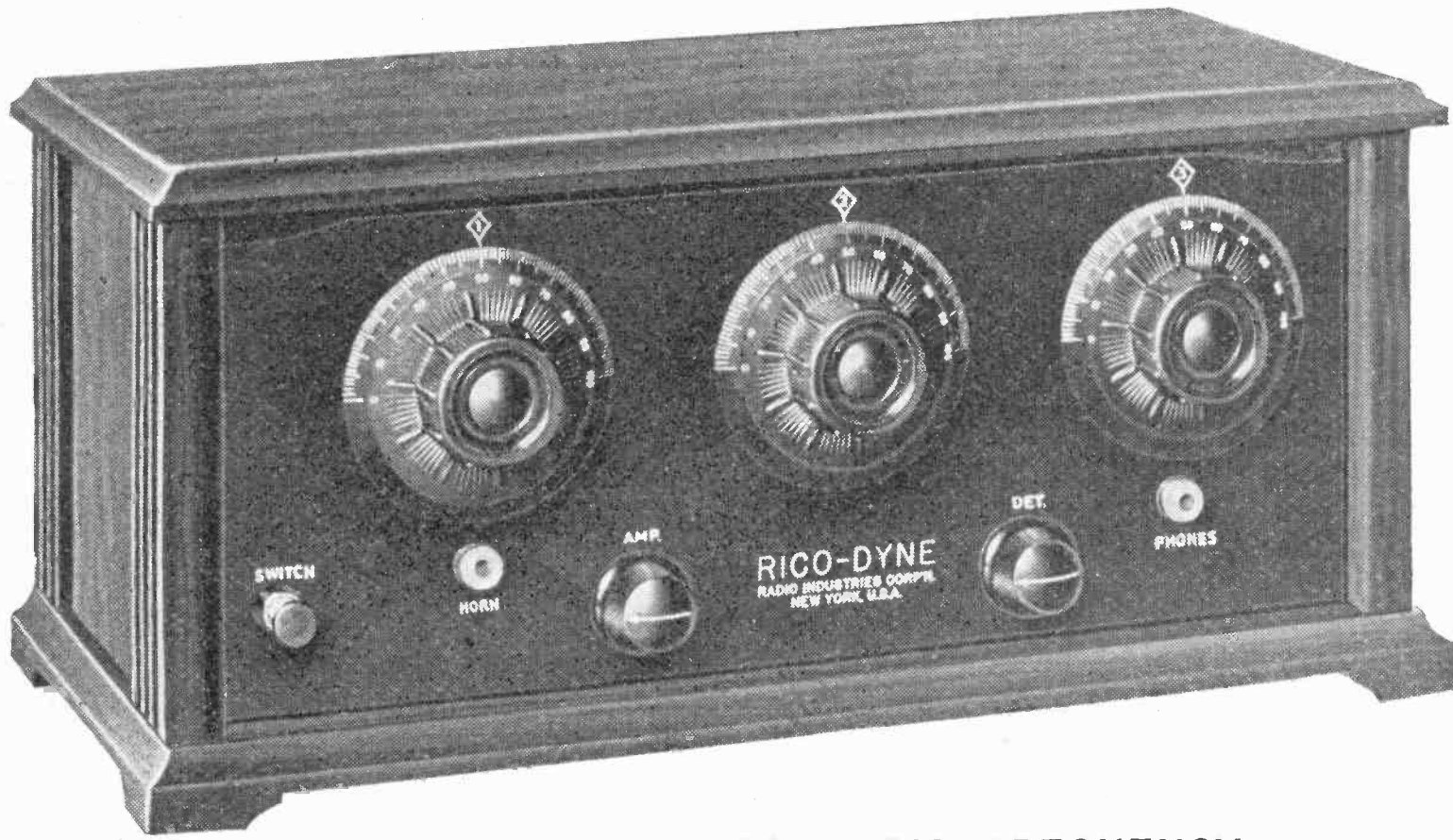

RICO-DYNE

An assurance of perfect performance, faithful tone production and \$100 radio receiver value, all for

\$60.

Mahogany Cabinet
The Set with a Punch

AUTO BALANCED 5-TUBE RADIO FREQUENCY

The combination of "RICO" CELLUWELD Low Loss Coils and Variable Condensers is made mechanically perfect. The Coils are welded firmly to the support of the rotor plates, our own patented principle.

Selective and non-oscillating, the "RICO" "AUTO-BALANCED" TUNED RADIO FREQUENCY SET accomplished by carefully setting the neutralizing angle of the Coils at the factory; remains permanent due to the CELLUWELD process.

The Complete Ricodyne Kit contains everything. The set you can build in 3 hours. Price Complete.....\$38.75

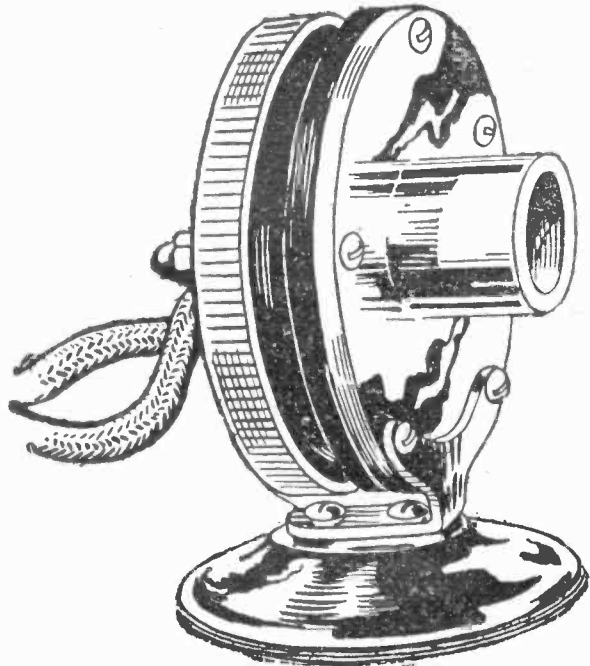

ADJUSTABLE

MAKE FULL USE OF YOUR PHONOGRAPH MELOTONE — "None Better"

Adjustable phonograph unit
makes your phonograph
a perfect loud-speaker

\$7.50

The Melotone Has All the Qualities of the \$10 to \$12 Units



THE NATION'S FAVORITE HEADSET

RICOPHONES — The Headset of Real Value

There is more quality, real honest-to-goodness quality packed into RICOPHONES than you'll find in any headset at twice its price! Compare and see.

\$2.95

Manufacturers of the famous "RICO" straight line condensers, at \$1.75 each. The "Tropadyne" circuit is supplied free with every tuned "Tropaformer" that we manufacture for all long wave transmission. "Tropaformers" \$6.75 each. Dealers—write or wire for wonderful proposition.

RADIO INDUSTRIES CORPORATION,
131 DUANE ST., NEW YORK CITY.

Gentlemen: I am enclosing \$..... for the items checked below. Kindly ship at once.

.....RICO-DYNE SET, \$60.

.....MELOTONE UNIT, \$7.50.

.....RICOPHONES, \$2.95.

My Dealer is

NAME

ADDRESS

CITY

RICO

for all
Long Wave
Circuits

RICO Products on this Page Will Improve Your Radio 100% TROPAFORMERS



The sensitivity, selectivity and volume obtained in all types of long-wave circuits depends entirely upon the intermediate frequency transformer. TROPAFORMERS have been specifically designed to meet the new scientific requirements of long-wave circuits. The TROPAFORMER combines transformer and condenser. The condenser is shunted across the secondary winding of the transformer, and by its use the transformer may be tuned to any definite wave length between 3,000 and 9,500 meters. Only in TROPAFORMERS will long-wave circuit users find these advantages, and these advantages are **\$6.75** patented for TROPAFORMERS exclusively!

Free Hook-up of the Famous Tropadyne Circuit with Each Tropafomer Ordered.

DID YOU EVER BUILD A SET THAT GOT "COAST TO COAST"?

You Can with the RICO-DYNE 5-Tube Auto-Balanced
Cellu-Weld Tuned Radio Frequency Kit **\$38.75**

Complete Knockdown Set as illustrated with full instructions how to build this marvelous set within a few hours.

Greatest Radio Value in History—This is What You Get:

1—Pair Ricofones. 1—Genuine Bakelite Front Panel, completely drilled and engraved. 1—Genuine laminated Bakelite Sub-Panel—with sockets already mounted. All mounting holes properly drilled. 3—Auto Balanced Tuned Radio Frequency Units—perfectly matched and balanced. 3—Beautiful 4-inch Dials. 1—Variable Grid Leak and .00025 M.F. Condenser. 1—4 to 1 Audio Transformer. 1—2 to 1 Audio Transformer. 1—.002 Fixed Mica Condenser. 1—.006 Fixed Mica Condenser. 2—Single Circuit Jacks. 1—Filament Control Switch. 1—30-ohm Rheostat. 1—10-ohm Rheostat.

FOR THOSE WHO WANT TO BUY ONLY THE RICO-DYNE KIT

HERE IS JUST WHAT THEY WANT:

It seems unusual that with the tremendous volume, selectivity and distance-range of the Rico Auto Balanced set, it should be so simple to construct. Yet, nevertheless, this is true. We have letters from fans who tell us that they constructed their Rico set within a few hours. The plans which accompany the Rico Kit are so simple that we believe this is so. Any beginner need only to read English in order to construct the Rico set. This Kit contains 3 Auto Balanced Tuned Radio Frequency Condensers, inductance Units, factory matched, book of instructions and drilling template. You can't go wrong!

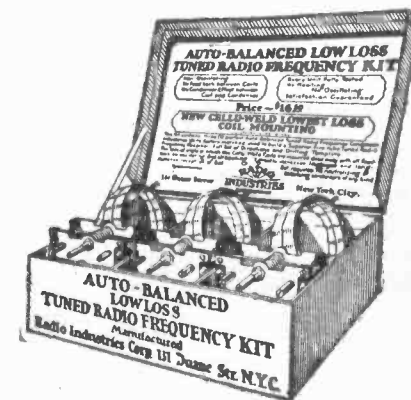

\$16.50

RICO-DYNE HAS SET
NEW RECORDS IN RADIO!

for
bliss!

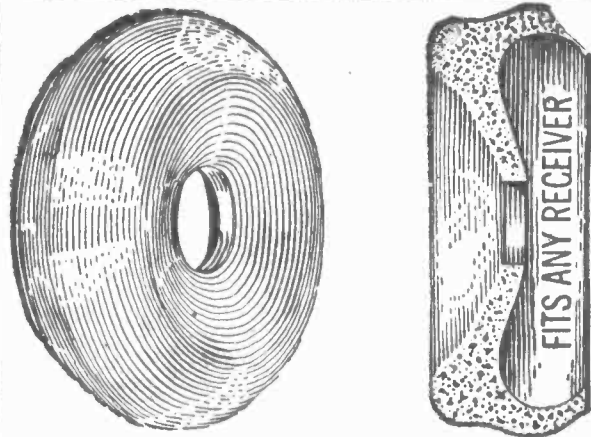

SPONGE RUBBER

RICO FONEKUSHIONS

You'll know what real ear-phone comfort is when you use RICO FONEKUSHIONS. They are made of soft, pure sponge rubber, and fit any make of headphone. They are like soft, downy pillows for your distance-seeking ears. **50c**

for
better
tuning

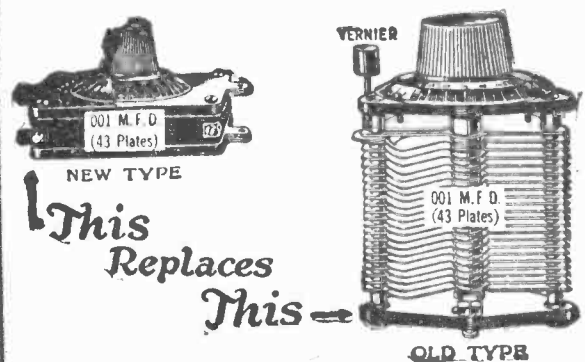

RICO STRAIGHT LINE CONDENSERS

In the old days, folks used horses. Now they can get as much power out of one auto as from 40 horses. It was all right, too, a few years ago, for folks to use the old-time condensers, but now, since Rico brought forth the RICO STRAIGHT LINE CONDENSER, which occupies two-thirds less space than the ordinary mesh plate type, everyone modernizes his set with the RICO STRAIGHT LINE CONDENSER.

No. 411—.00025 mfd. \$1.75
No. 423—.0005 mfd. 1.75
No. 450—.001 mfd. 1.75

Inclusive with Dials. Without Dials, \$1.50.

Each of these
Rico products
means added
pleasure and
value to your
Radio Set.

If Your Dealer Cannot Supply You—Use This Coupon. No Money Down!

RADIO INDUSTRIES CORPORATION
131 Duane Street, New York City

Please send me C. O. D. the following: Tropafomers, \$6.75 Straight Line
Condensers, \$1.75 Ricofones, \$2.95 Oscillating Coil, \$3 Fonekushions, 50c
. Melotone Attachment, \$7.50.

Name Address

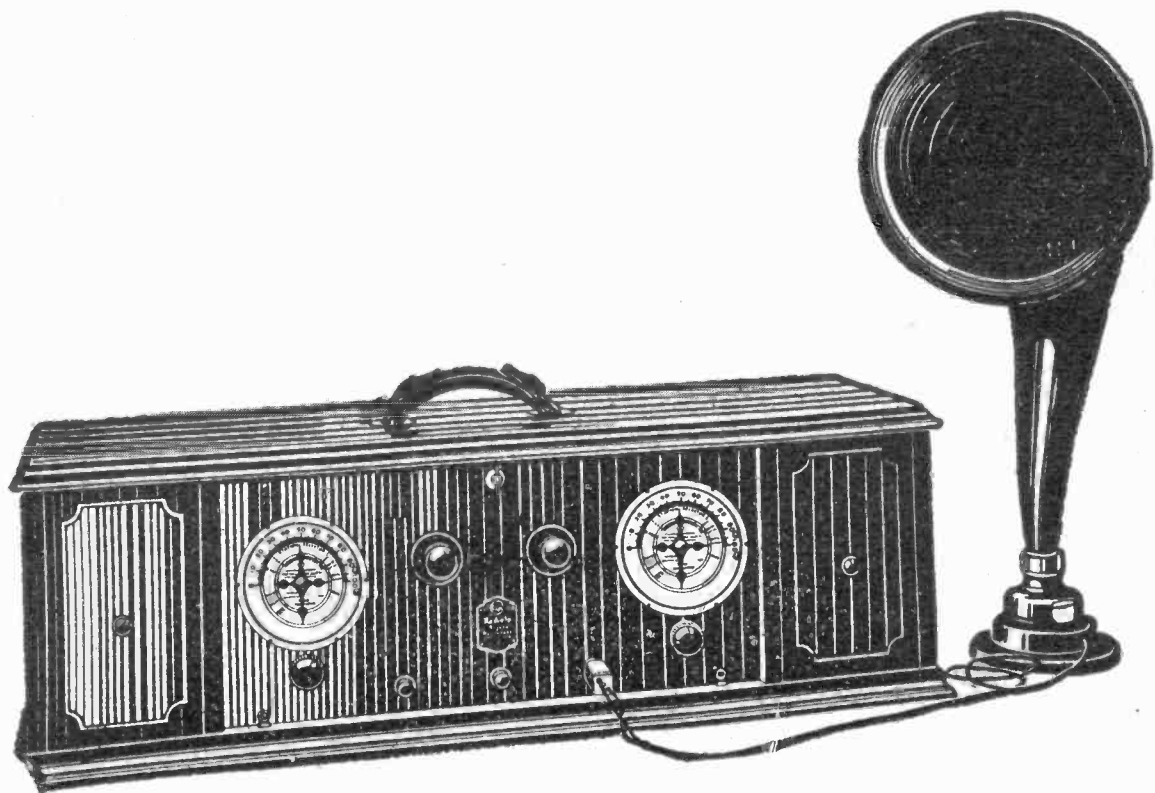

Which is Better—

**A Cheap Set for Cash---or
A GOOD Set ON TERMS**

?

The Good Set is Cheapest in the End

Bay State specializes on the better grade sets, like Radiola, DeForest, Adler Royal, Magnavox, and sells on **Convenient Terms.**

Write for information. Address Dept. A,

BAY STATE RADIO CO.

The House of Radio Service

116A Washington Street

Boston, Mass.

GRAND CENTRAL PALACE

4th Annual NATIONAL RADIO EXPOSITION

Grand Central Palace, New York
September 12th - 19th incl.

- the fourth successive national exposition representing all the leading manufacturers of the radio industry;
- the only great radio exposition of 1925 to be held in the metropolitan center of New York;
- the greatest spectacle of the year in the scientific, industrial and business progress of radio!

Business Office.
AMERICAN RADIO EXPOSITION CO
522 Fifth Avenue, New York

HAROLD BOLSTER, Director
J. C. JOHNSON, General Manager

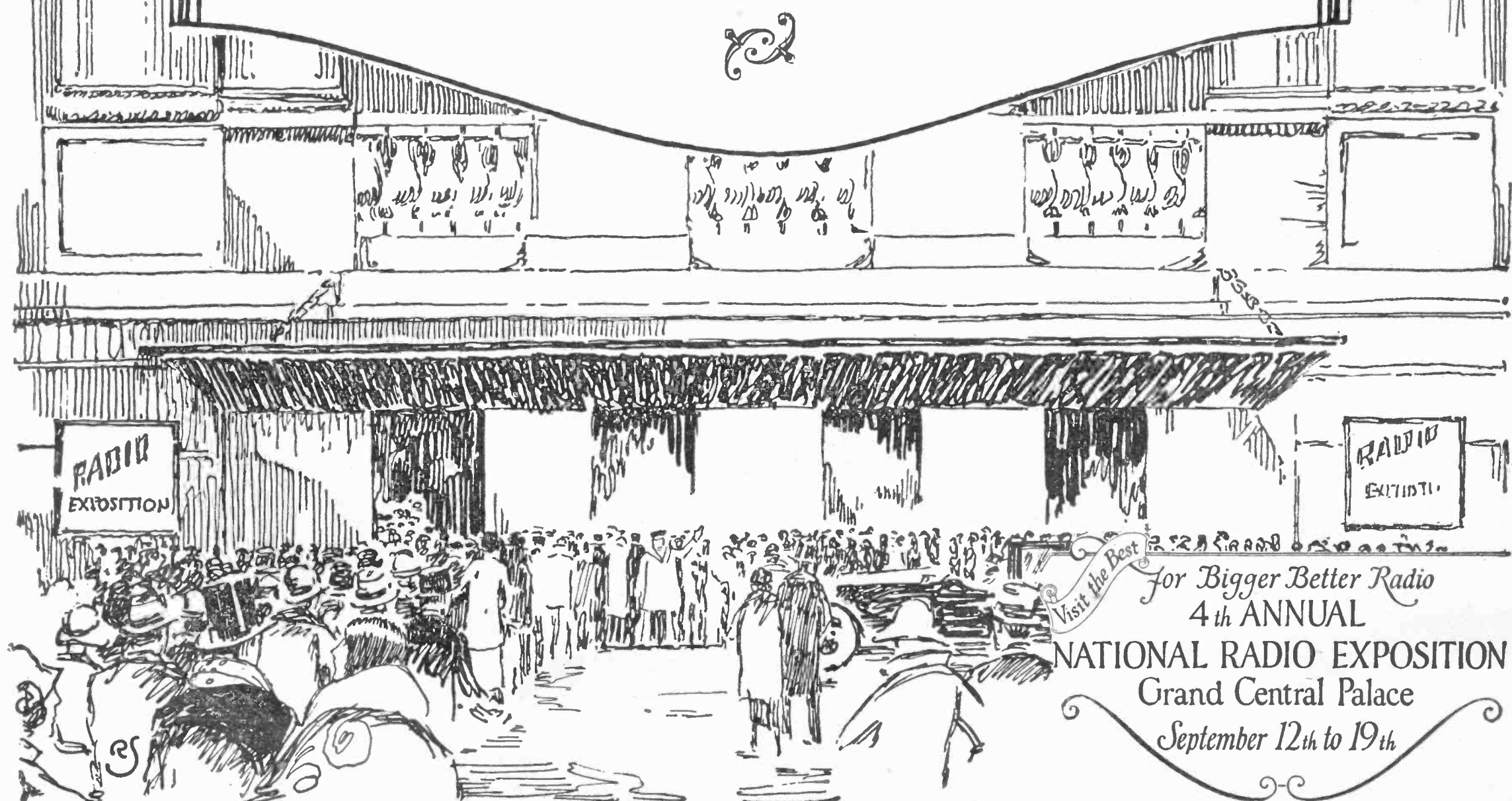

RADIO PROGRESS

HORACE V. S. TAYLOR, EDITOR

Volume 2

Number 13

Contents for SEPTEMBER 15, 1925

	PAGE
HOW YOUR GRID LEAK IS MADE	9
WHAT METAL YOU SHOULD USE	13
SOME TESTS ON SIGNAL STRENGTH	15
AMERICAN RADIO RELAY LEAGUE	18
GIVE THAT SMART LOOK TO YOUR PANEL	19
DON'T TRY TO BEAT THE PATENT LAWS	22
HOW THE NAVY CUT OUT STATIC	23
BROADCASTING FROM THE POLAR SNOWS	25
EDITOR'S LOUD SPEAKER:	
RADIO THE NEW DEB	29
THINKING IN MILLIONS	29
TALKING UP IN THE AIR	30
THE HOLE IN THE WALL	30
WHAT'S NEW AT NEW YORK RADIO SHOW	31
FONE FUN FOR FANS	33
NEW PRODUCTS OF UNUSUAL INTEREST	34
DR. RADIO PRESCRIBES	36
U. S. BROADCASTING STATIONS	38

New York Representative

SHELDON C. KNIFFIN 503 Fifth Avenue, New York—Phone Murray Hill 3149

Western Representative

W. T. DIEHL 30 North Dearborn Street, Chicago—Phone Central 5410

RADIO PROGRESS is issued on the 1st and 15th of each month by the Oxford Press at 8 Temple Street, Providence, Rhode Island. John F. O'Hara, Publisher. Yearly subscription in U. S. A., \$3.00. Outside U. S. A., \$3.50. Single copies, 15 cents. Entered as second-class matter, April 4, 1924, at the Post Office at Providence, R. I., under the Act of March 3, 1879. Address all communications to RADIO PROGRESS, 8 Temple Street (P. O. Box 728), Providence, R. I. Title registered at United States Patent Office.

The publishers of this magazine disclaim all responsibility for opinions or statements of contributors which may at any time become subject of controversy.

The Two Outstanding Parts In Radio !

Give Low Losses and Amplification Without Distortion to Any Set

QUANTITY and distance are what a radio set must give. To insure Quality, amplification without distortion is essential. And to insure Distance, low losses are essential. That is radio in a nutshell.

People in whose sets Acme Transformers are used, are sure of hearing concerts "loud and clear" so a whole roomful of people can enjoy them.

The Acme A-2 Audio Amplifying Transformer is the part that gives quality. It is the result of 5 years of research and experimenting. It gives amplification without distortion to any set. Whether you have a neutrodyne, super-heterodyne, regenerative or reflex, the addition of the Acme A-2 will make it better.

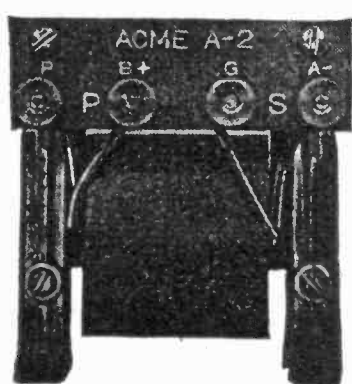

Acme A-2 Audio Frequency Amplifying Transformer

To get the thrill of hearing distant stations loud and clear, your set must have low losses, for it is low losses that give sharp tuning to cut through the locals, and it is low losses that allow the little energy in your antenna to come to the amplifier undiminished. That's what the Acme condenser will do for any set. And it will do it for years, because the ends can't warp, the bearings can't stick and the dust can't get in and drive up the losses several hundred per cent.

The Acme Reflex (trade mark) owes its success and its continued popularity to these two outstanding parts in the radio industry, for low losses and amplification go hand in hand.

Use these two parts in the set you build. Insist on them in the set you buy.

Send 10 cents for 40-page book, "Amplification without Distortion"

WE HAVE prepared a 40-page book called "Amplification without Distortion." It contains 19 valuable wiring diagrams. In clear non-technical language it discusses such subjects as Radio Essentials and Set-building; How to make a loop; Audio frequency amplifying apparatus and circuits; Instructions for constructing and operating Reflex amplifiers; How to operate Reflex receivers; Antenna tuning circuits for Reflex sets; "D" Coil added to Acme four tube reflex; "D" coil tuned R. F. and Reflex diagrams; and several more besides. It will help you build a set or make your present set better. Send us 10 cents with coupon below and we will mail you a copy at once.

ACME APPARATUS COMPANY

Transformer and Radio Engineers and Manufacturers

DEPT. (AS), CAMBRIDGE, MASS.

SEND THIS COUPON

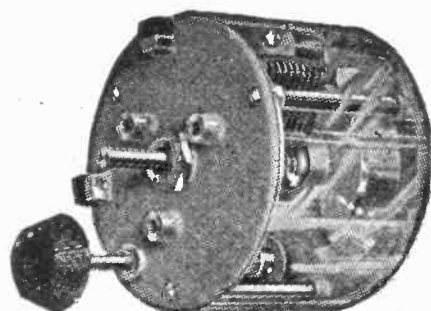

Acme Low-Loss Condenser

ACME APPARATUS COMPANY,
Dept. (AS), Cambridge, Mass.

Gentlemen:—

I am enclosing 10 cents (U. S. stamps or coin) for a copy of your book "Amplification without Distortion."

Name

Street

City..... State.....

ACME ~ for amplification

You Will Like the Menu for the October 1 Issue

DeForest was the man who invented the ordinary vacuum tube. When he announces his new ideas all the world listens. He has recently made several startling improvements which are described and illustrated by Arnold in **"DeForest Develops Some Novel Devices."**

There has been quite a lot written about the trend of waves towards the fast or short length. But few experimenters know how to build a first-class receiving set to pick up these speedy waves. When you have read, **"Build a Fast-Short-Wave Set,"** by Rados, you will be able to construct such a radio yourself.

You keep hearing announcements of "A" and "B" broadcasting stations. Do you know what the difference is between them? An explanation and a discussion of how the government assigns these ratings appears in the article by Vance, **"A and B Broadcasting Stations."**

We all know what sound is and also have a pretty good idea of what is meant by an electric current. But is it well understood how the sound of your voice is changed into the electricity whose waves come sweeping through the air. Steinmetz has a contribution which makes it clear, **"Changing Sound Into Electric Current."**

When you hear a whistle it is often the fault of your own or a neighbor's receiving set. But sometimes it is the fault of the broadcasting station. A slight change of wave will make a squeal which no receiver can cure. Why this occurs and how one big sending station has absolutely prevented it is written up by Taylor in **"Crystal Cures the Birdies at KDKA."**

One of the most popular artists before the microphone once had quite a legal fight as the Sultan of Sulu. This interesting bit, as well as other interesting incidents of his life are well told by Moulan.

The Department of Commerce decides on how much power any sending station is allowed to put on the air. They were partners with the General Electric Company in the recent test at 50,000 watts. You will find the Department's report quite entertaining. Read **"Hoover's Bureau Favors Superpower."**

As autumn approaches you may want to transport your radio set. The way you pack it for shipment will make all the difference in the world as to how it is received at the other end. Probably the best authority on this is the American Railway Express. What they have found out about transporting radios is told by Todd in, **"Packing a Radio for Shipment."**

RADIO PROGRESS

"ALWAYS ABREAST OF THE TIMES"

Vol. 2, No. 13

SEPTEMBER 15, 1925

15c PER COPY, \$3.00 PER YEAR

How Your Grid Leak is Made

*There Are Several Styles
from Which You May Choose*

By HORACE V. S. TAYLOR

THERE is the story of the man who drove an automobile several months before he learned that there was such a thing as a storage battery on board his car. That was probably worse than the radio fan who operates his tube set without knowing anything about his grid leak, but that is no excuse for the latter.

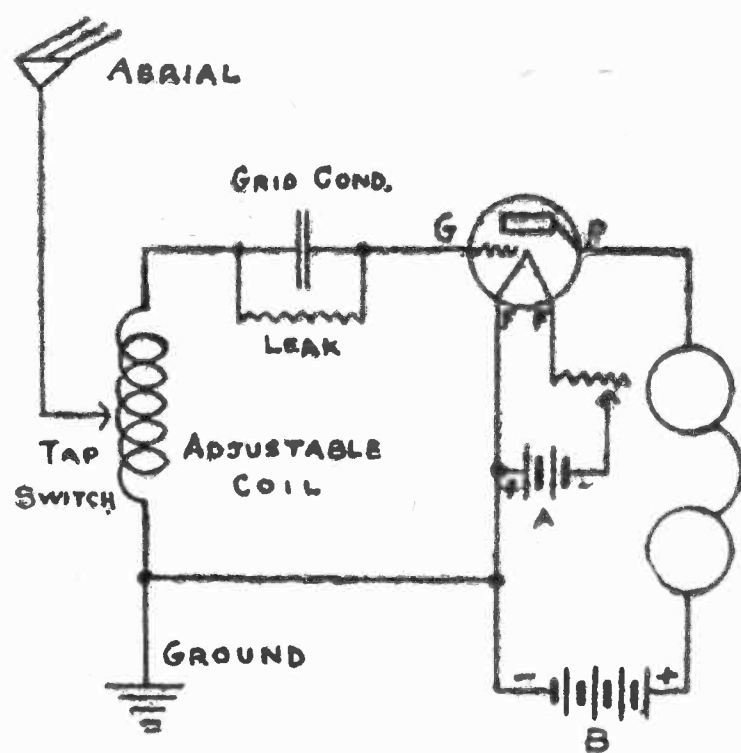

Fig. 1. This Hook-up Shows How Leak is Connected

Perhaps you may call to mind some set (remember we are not talking about crystal sets in this article) which has clips for a grid leak and yet no such unit is installed. However, that does not mean that it is working without a leak. There always must be one or else the tube will stop operating in a fraction of a second.

Tube Like a Furnace

It is very much like the different ways of installing a hot air furnace in your cellar to warm your rooms in the winter time. All the newer installations have a cold air duct connecting the base of the

furnace to an opening in the basement walls, and this serves to conduct the air from outside the house into the furnace, where it is heated and ascends to your rooms above.

Some of the older installations, however, neglected this duct and instead took the cold air from the cellar itself, which was warmed and sent upstairs. In this case the air which is heated certainly comes from somewhere. It could not be consumed from the cellar itself without being replaced, as such an action would cause a vacuum and the circulation would stop in a very short time. As a matter of fact, the various windows, doors and cracks around pipes and the like let in enough air to the cellar to furnish that used by the heating system. Of course this idea is not as good as having a definite duct which may have a damper for controlling its action.

Where the Leak is Found

You certainly would not say because you see no duct at the base of your furnace that no air was passing up the hot air pipes. You can feel the higher temperature in upper rooms and you know that the air must be leaking in from somewhere. In the same way a set which has apparently no grid leak may work fairly well because the leakage over the insulation and through the socket base may be enough to approach the right value. No insulation (except a vacuum) is perfect, and a small amount of leakage goes on all the time from your grid terminals, wires and connections. However, a definite grid leak will be an improvement unless the set already has so many conducting paths

that the resistance is already too low. Such cases, however, are not very frequent.

The electrons, which are shot off by the filament of the vacuum tube, shoot across to the plate under the attraction of the positive charge furnished by the "B" battery. However, a small proportion of these negative particles fall by the wayside—in other words, strike the grid wires and yield their charge to this element. This builds up a negative potential on the grid.

Grid Blocked Without Leak

If there were an electric conducting path between the grid and the filament, this charge would immediately leak back to the filament, but the grid condenser allows no direct current or leakage of a charge to pass. The result would be that if there were really no leakage at all the charge on the grid would become more and more negative as the electrons piled up on it, until at last the repelling action exerted on the electrons leaving the filament would be tremendously great. "Like repels like" is the rule for electricity, and as a result no more elec-



Fig. 2. Most Non-adjustable Leaks Take This Shape

trons would be able to get through the strong negative field of the grid and so the plate would no longer receive any of these tiny visitors which make up the plate current. This is called "blocking."

Fig. 1 is the hook-up for a simple set using a leak and condenser. Although

the tuning coil is connected between the grid and filament as usual, the presence of the condenser allows only high (radio frequency) oscillations to pass, and the charge of direct current which is built up by the stray electrons inside the tube cannot get away. By putting in the grid leak as shown it allows this charge to be dissipated and so prevents blocking of the tube.

more sensitive than that of using a *steady* bias from a "C" battery. And then a "C" battery must be renewed every few months, which is a bother and an expense, while a grid condenser and leak will last indefinitely.

Don't Worry About Small Changes

From this you can see that to get the right average voltage on the grid you must use a leak with the right amount

menter to play with and further, even if this is not monkeyed with, the resistance of the leak may change from time to time and the unit may even become worthless through wear if the adjustment is manipulated too often.

A form of fixed leak which is very popular appears in Fig. 2. The end caps form the conducting terminals for the high resistance inside the tube. There are several ways of making such a device. One is to make a paste of finely divided carbon, which is usually obtained in the form of lamp black. This is mixed with some non-conductor, like paper or clay, and the whole thing mixed into a smooth mass.

Squeezed Into a Ribbon

This is then put into a sort of pump where a piston presses on the paste contained in a cylinder. At the end is a small hole through which the doughy mass is squeezed in the form of a fine



Fig. 3. This Principle Explains Why Leaks Consisting of Separate Grains Are Not as Good as Those with a Continuous Resistance

By using the proper value of leak, the average voltage or bias on the grid is kept as a value which gives the greatest amount of loudness from your detector tube. Notice that we say the *average* voltage. As a radio signal comes in the oscillations coming down from the aerial, through the tuning coil, pass easily through the capacity of the condenser and so are impressed on the grid. This fluctuation causes a similar change in the quantity of electrons getting across from the filament. Another result is that the number striking the grid varies from instant to instant, and so the grid potential also changes. As soon as the audio waves stop for an instant the grid potential is immediately restored to its average value and the action is ready to begin all over again.

You may wonder why it is not better to use a "C" battery on the detector instead of a grid leak and condenser. As a matter of fact, this is sometimes done and it works very well. However, there are two disadvantages of this scheme. In the first place it is found that the changes in average bias on the grid make this scheme of detector action

of resistance. To be sure, this is not very critical, and a change of 10 or 20 per cent has practically no effect. But if the set has say twice or half as much resistance as it should, then the reception will be not nearly as good.

There are two general classes of leaks, —the fixed and the adjustable. The advantage of the former is its simplicity and cheapness. The objection to it is that in many sets the right value of megohms is not used. (A megohm you recall is one million ohms.) To be sure, in adjusting your set you may try out values labelled 1, 1½, 2, 3, 4, etc. But you must remember that the figures on its label means nothing in the life of the average grid leak. Still, if you use a reliable brand, which has been tested, then you can believe that the labels are telling the truth.

Meet the Variable Leak

The other style of unit is the adjustable leak. This has the advantage that you do not need to pay any attention to the label at all, as you make your own value of megohms. The disadvantages here are that the adjusting handle is a tempting device for the experi-

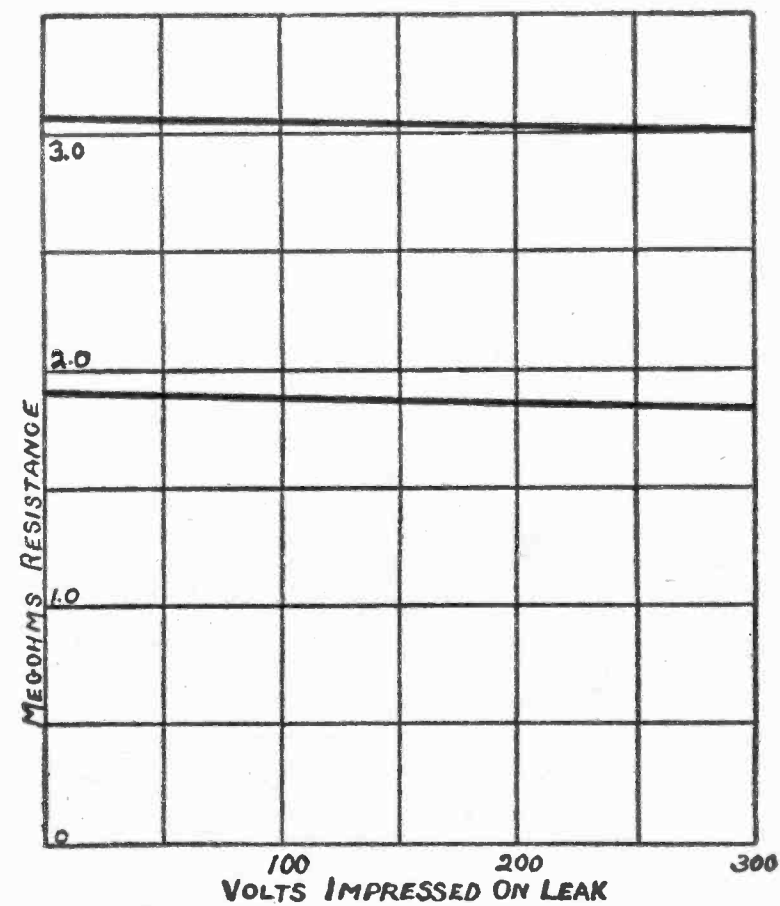

Fig. 4. A Good Leak is Quite Steady in Resistance, Even with Varying Voltage.

ribbon. This is dried and then attached to metal ends. The latter are finally soldered to the brass ferrules, which are seen at the ends of practically all non-adjustable leaks.

Another type of high resistance is obtained by cutting absorbent blotting paper into narrow strips and soaking these in India ink. The latter has very finely divided carbon for its basis. This is eagerly sucked up by the blotting paper and when dried forms a conducting path with a very high resistance for its length.

Both these processes give good results when carefully worked out. However, there is a good deal of chance for variations in manufacturing with resultant lack of uniformity in the resistance. Of

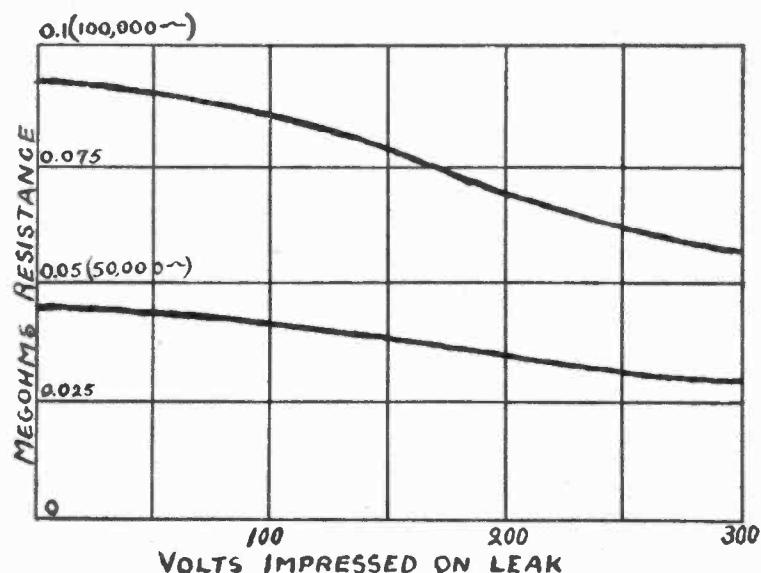

Fig. 5. This Leak is for Use in a Resistance Coupled Amplifier

course, too, such units may easily be affected by high humidity.

Spinning a Wire of Glass

Another way of making grid leaks has recently been developed by Durham & Company. They use a very thin metallic film deposited on glass. As they report on this process, the apparatus for making the resistance filament consists of an ingenious and very efficient machine for the spinning of glass into a small wire shape of uniform diameter. This glass is spun in lengths of five hundred feet, wrapped on a reel, passed through a solution of the conducting material, then through a high temperature furnace through which furnace a steady flow of gas is maintained. A metal by-product of zinc is reduced to gas and through a process of heating the fine glass filament this metallic gas is "thrown down" or flashed on to the outer surface in varying degrees of thickness, depending upon the resistance that is required.

The glass wire with its conducting film is next coated in a chemical bath of insulating fluid and dried by the application of heat. The conducting film is thus thoroughly protected against atmospheric changes.

Keeping the Meters Right

This metal-coated filament is then aged for a period of several days to enable the glass to reach its original consistency. The wire next goes to a department where it is cut into actual lengths required for the grid leak assembly, and where it is soldered to the end brass caps comprising the contacts at either end of the grid leak. This work is done by very skilled workers who are each capable of assembling in the neighbor-

hood of five hundred leaks per day. After assembly the leaks are tested and stored in trays. The meters used for such tests are, for the sake of accuracy, constantly checked against laboratory standards.

The metallic form of leak has some advantages. In the carbon type, even if the resistance is properly labelled at first, there is a chance that it might change in value. Carbon has a rather high temperature co-efficient which causes a lowering of resistance as the material gets hotter. This is just the opposite of most every metal whose re-

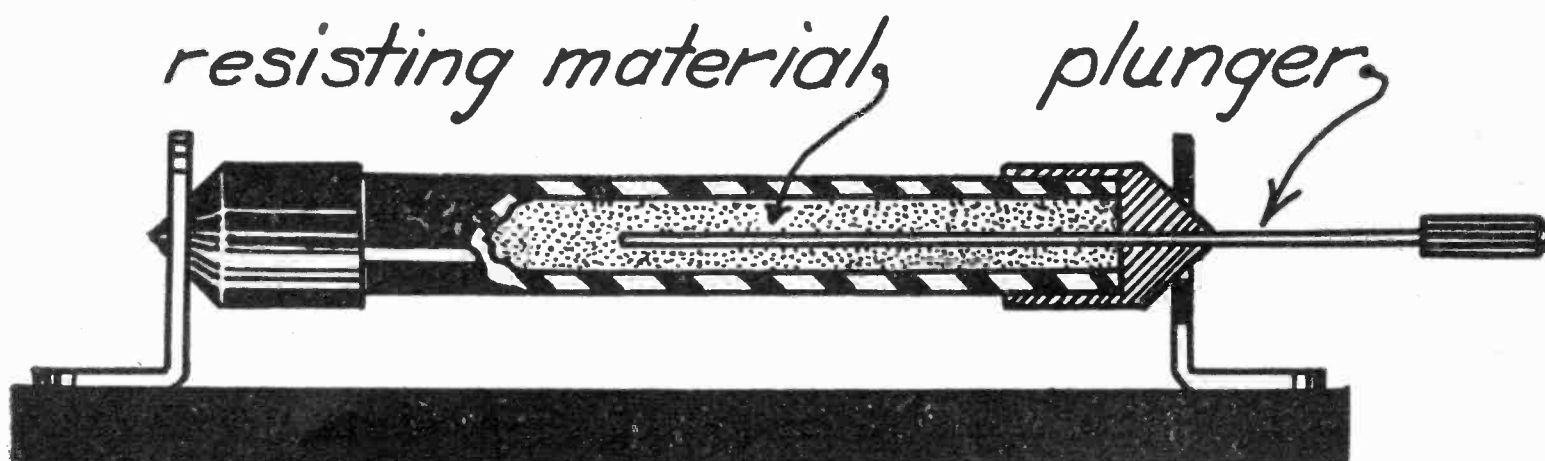

Fig. 6. The Basic Principle of Most Variable Leaks

sistance almost invariably increases with rising temperature. This effect, however, is not at all serious since the radio set never gets above room temperature and the fluctuations of heat between summer and winter are not great enough to cause much effect.

Claim There is Arcing

Some manufacturers claim with carbon leaks that the passage of the current through the carbon resistance causes minute arcing between the particles of carbon which although not visible to the eye may be clearly heard in the form of hissing and scratching noises when subjected to high voltage or sudden impulses. This is particularly noticeable in such circuits as resistance coupled amplifier circuits, filter circuits, and even in the grid circuit they are subject to fluctuations of potential.

This theory, however, is in error. It has been found that the voltage necessary to maintain an arc does not decrease with the spacing between the electrodes when they are separated by microscopic distances, as they are in the leak. In other words, the voltage necessary to form such a tremendous number of arcs in series would be enormous. Instead of this the pressure from the electron charge on a grid leak is only a small fraction of a volt. There is no arcing at all in a grid leak.

What Makes the Noise

However, it is quite true that many leaks make a lot of noise. The cause of this disturbance is to be found in the varying resistance which carbon has when subjected to a change of pressure. This is the action which you get in an ordinary telephone transmitter or in a microphone. The slightest vibration on a carbon path will cause an electrical noise if the particles of the material happen to be in the right condition of spacing and pressure.

This idea may be seen more clearly from Fig. 3. Here we have a path of

stepping stones across the river. In the background we see a bridge. When the stones are working right the girl passes over them without any trouble at all. However, you can easily imagine that a slight disturbance here would have more effect on her smooth passage than a similar disturbance in the path of the man across the continuous bridge.

Voltage Leaves Resistance Unchanged

As an example of how constant the metallic grid leaks are, Fig. 4 shows the variation in resistance with different degrees of voltage impressed across them. The lower curve is for a two megohm leak and the upper for a value of three megohms. Notice that although they fall off very slightly they are almost steady in value way up to 300 volts. Of course, this high pressure would never be used in actual practice.

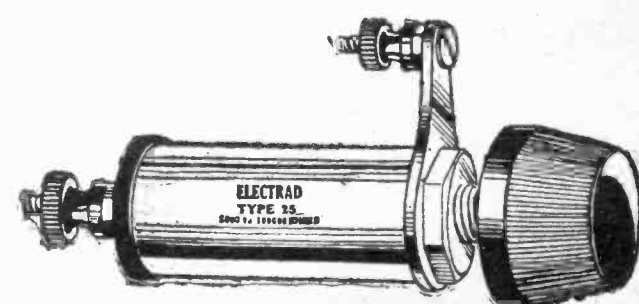

Fig. 7. The Variation in This Unit is Obtained by a Screw

A lower resistance for use in a resistance coupled amplifier must carry a great deal more current than an ordinary grid leak. It is therefore, not so

easy to build and is more expensive. Curves of the performance of such units appear in Fig. 5. The upper curve is for 90,000 ohms and the lower for 40,000.

Another form of resistance is illustrated in Fig. 6. We are now in the variable leak class. Several manufacturers use this general idea, but modified to suit their own processes. A tube is filled with a high resistance material and a metallic plunger carries the cur-

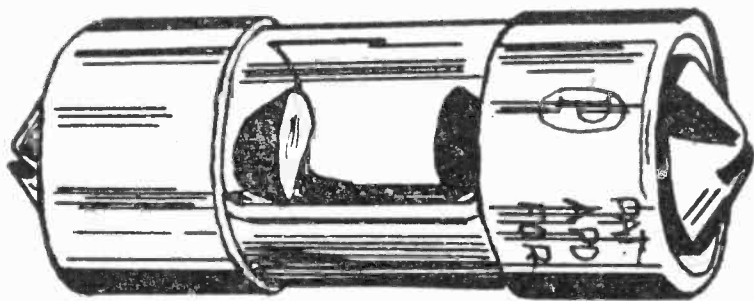

Fig. 8. The Liquid in Tube Touches More or Less of the Half-circle Ends

rent and so short-circuits practically the entire amount of high resistance. This gives a low number of megohms, perhaps as small a value as 1/10.

Raising the Megohms

As the plunger is withdrawn to the right it leaves more and more of the resistance in the path of the current. When pulled way out there is no metal in circuit and so the resistance of the leak is at its highest—10 or 20 megohms depending on what kind of material fills the tube. One popular kind is Prussian Blue.

Fig. 7 shows the form of adjustable leak put out by the Electrad Company.

Instead of sliding a plunger back and forth, a screw is used which gives very fine adjustment. It is also easy to mark the position of such a handle. It takes up considerably more space than the type shown in Fig. 6.

Another very ingenious way of changing the value of resistance is displayed in the "Turnit." This, as you see from Fig. 8, has the general shape of the ordinary grid leak except that it is much larger in diameter. The glass tube contains a liquid which has two electrodes dipping into at the ends. Most of the resistance of the tube lies at the contact between the electrodes and the liquid. This leak must be used in a horizontal position.

The electrodes are shaped like half circles. When the whole container is turned so that these half circles are dipping deep into the liquid, then the resistance of the unit is at its lower value. By rotating the tube so that the half circles are up out of the liquid instead of dipping into it at the ends, the ohms rise to a high value. Of course, intermediate positions give results between these two values.

One more kind of leak should be mentioned. This is the home made variable shown in Fig. 9. It is made right on the grid condenser by drawing pencil lines across from one terminal to the other. The current follows these lines and so relieves the grid of its blocking charge.

Juggling with the Megohms

The more lines there are in parallel, the more current will be conducted, or

in other words, the lower the resistance of the leak. If you have too many megohms, then draw a line or two across. If you get reckless and put on too many lines and so drop the megohms to a resistance which is too small, then the remedy is simple. Take out your eraser and rub a few of them off. As the lines disappear the megohms pile up again.

In making this style of leak, one caution is necessary. If a rope breaks in only one place it will not hold much

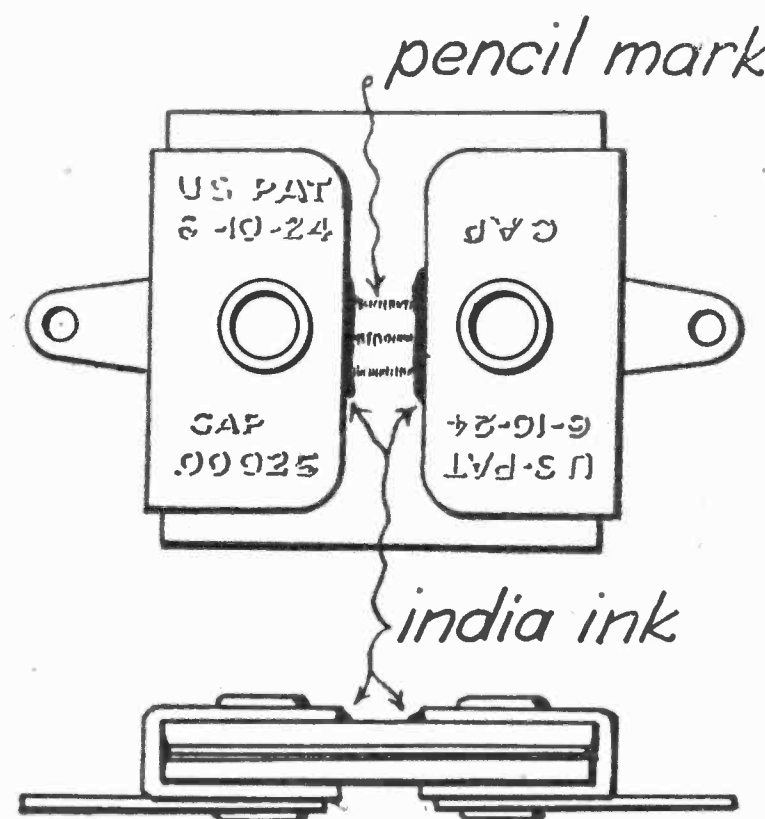

Fig. 9. The Home-made Leak. Don't Omit the India Ink

weight. And if a pencil line reaches almost all the way to the metal end it will carry no current. In other words, the pencil mark must actually touch the end conductor to be of any value at all.

Filling in the Cracks

That is where most home-made grid leaks fail. The metal cap at the end of the condenser stands up a little way as shown at the bottom of Fig. 9. A lead pencil, even with a very sharp tip, cannot get into the extreme corner. To get away from this difficulty, after several lines have been drawn, fill in the cracks at the bottom of the metal caps with a small amount of India ink, either the cake form or an ordinary liquid drawing ink like Higgins is satisfactory. This ink, as already explained, has a carbon base, and will carry the pencil line up into good contact with the metal.

Such a grid leak when well made is easily adjusted and is fairly constant in value, although of course, it is not as stable or as conveniently used as one of the manufactured articles, which we have described.

RADIO PROGRESS
 8 Temple St. (P. O. Box 728)
 Providence, R. I.

Date.....

You may enter my subscription to **RADIO PROGRESS**

for.....year { 1 year \$3.00
 2 years \$5.50

Signature.....

Send it to this address

Paid by (PRINT)

Check

Cash

Money order

What Metal You Should Use

Do You Want a High Resistance Or Perhaps a Heavy Weight?

By OLIVER D. ARNOLD

ONE of the commonest properties of metals used in electrical work is their resistance. It is this quality which has made copper the most used wire of the electrician.

Of course everyone knows that comparing with a current of water a large pipe will carry more than a small one. Thus in Fig. 1, the one-inch pipe has a diameter twice as big or an area four

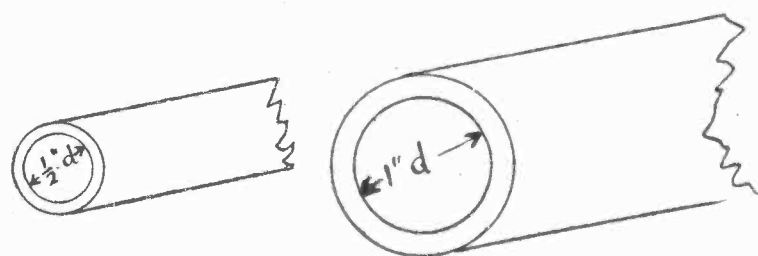

Fig. 1. Twice the Diameter Gives One-fourth the Resistance for Water or Electricity.

times as large as the 1/2-inch pipe. It will, therefore, carry four times the water. Another way of expressing this is to say that the smaller pipe has four times the resistance of the larger.

Water Like Electricity Here

In the same way a wire with twice the diameter will have four times the area of a smaller size and the latter will also have four times the electrical resistance. There is one big difference, however, between conductors of water and of electricity.

It makes no difference whether the water pipe is made of copper or iron, or even fibre, provided that the inside surface is equally smooth. But what a difference when one of these materials is used in a radio set. The iron wire will have six times the resistance of its copper equivalent, while the fibre rod will not conduct at all, which means that it is all resistance.

Another interesting point is in regard to temperature. Of course you know that in summer time metal objects are somewhat bigger than in winter. On a hot day you are apt to take off your coat and stretch out your arms, while in win-

ter you may huddle up as small as possible from the effect of the cold. Almost all materials do about the same thing. That is what makes mercury rise in a thermometer when it is warm and contract under the influence of cold.

Better Set in Cold Weather

However, size is not the only thing changed by the temperature. Your radio set is not quite as selective on a hot day as it is in winter. This change, although small, is brought about by the fact that the wire increased its resistance under the influence of heat. This affect is called its temperature coefficient.

The next thing that comes to mind about a metal is its weight. Until recently no one had any idea why lead was heavier than aluminum. Recent experiments in the laboratories have proved

that weight is a property of the atom and that heavy metals have a large number of negative electrons with their positive partners, or "protons," while the light elements contain only a few of exactly the same building materials.

Why is steel used as the skeleton of a sky scraper? Because it is so strong. There are two ways of measuring this strength—one by pulling the specimen in two, and the other by compressing it. For most purposes the first of these is what is required. In this way a rope or a chain depends for its usefulness entirely on its tensile strength. A brick on the other hand is never subject to pulling apart, but is always under compression.

Hardness Affects Strength

Fig. 2 shows these properties as displayed in the common metals. The first

Metal	Relative Resistance	Temperature Co-efficient	Specific Gravity	Tensile Strength Lbs.
Aluminum.	2.8	0.0039	2.7	30,000
Antimony.	41.7	.0036	6.6
Bismuth.	120.0	.004	9.8
Brass.	7.0	.002	8.6	70,000
Cadmium.	7.6	.0038	8.6
Constantan.	49.0	.00001	8.9	120,000
Copper, annealed.	1.72	.0039	8.89	30,000
Copper, hard-drawn.	1.77	.0038	8.89	60,000
Gold.	2.4	.0034	19.3	20,000
German Silver (see nickel silver)				
Iron, 99.98% pure.	10.0	.0050	7.8
Lead.	22.0	.0039	11.4	3,000
Magnesium.	4.6	.004	1.7	33,000
Manganin.	44.0	.00001	8.4	150,000
Mercury.	95.7	.00089	13.5
Molybdenum, drawn.	5.7	.004	9.0
Nichrome.	100.0	.0004	8.2	150,000
Nickel.	7.8	.006	8.9	120,000
Nickel Silver, 18% Nickel.	33.0	.0004	8.4	150,000
Palladium.	11.0	.0033	12.2	39,000
Phosphor Bronze.	7.8	.0018	8.9	25,000
Platinum.	10.0	.003	21.4	50,000
Silver.	1.6	.0038	10.5	42,000
Steel, soft.	10.4	.005	7.7	53,000
Steel, Siemens-Martin.	18.0	.003	7.7	100,000
Steel, Manganese.	70.0	.001	7.5	230,000
Tantalum.	15.5	.0031	16.6
Tin.	11.5	.0042	7.3	4,000
Tungsten, drawn.	5.6	.0045	19.0	500,000
Zinc.	5.6	.0037	7.1	10,000

Fig. 2. This Table Was Worked Out by the Bureau of Standards. It Gives Useful Data on All the Usual Metals.

column gives the name of the element of alloy. In a few cases the mechanical treatment affects the material. Thus hard drawn copper is a lot stronger than annealed.

Col. 2 shows the relative resistance. Iron is called 10, and on this scale nichrome, which is one of the standard heating units for flat irons, rheostats, and the like, becomes 100. The values in this table are also the exact resistance in ohms of a wire 100 meters long and 1 millimeter square, taken at 68 degrees Fahrenheit.

Col. 3 gives the temperature coefficient. This is the proportion which the resistance increases for each degree centigrade of temperature. Thus, for brass, if you heat it up one degree, it will increase its resistance .002 or 2/10 of 1%. That means that for every five degrees the resistance will go up 1%.

What a Pint of Metal Weighs

Col. 4 gives the specific gravity of the metal. This is defined as the ratio of its weight compared to water. Aluminum, for instance, is $2 \frac{7}{10}$ times as heavy as water. As it happens that a pint of water weighs just about a pound, it follows that the figures given in this column are the weights of a pint of each material.

The last column gives the strength of the materials in pounds per square inch. This represents the weight necessary to pull in two a bar one inch square. Of course the shape of the cross section does not make any difference as long as it has one square inch of area. Aluminum will support a weight up to 30,000 pounds or 15 tons before a square inch of it will break.

Gold is Not as Good

Some interesting facts may be learned

from this table. You will notice that silver has the lowest resistance of anything and so would make the best wire for winding your coils in a radio set. Of course the objection to it is its very high price. However, copper is almost as good and so is universally used for windings. Many people talk about using gold wire in extra fine sets, but you will see how

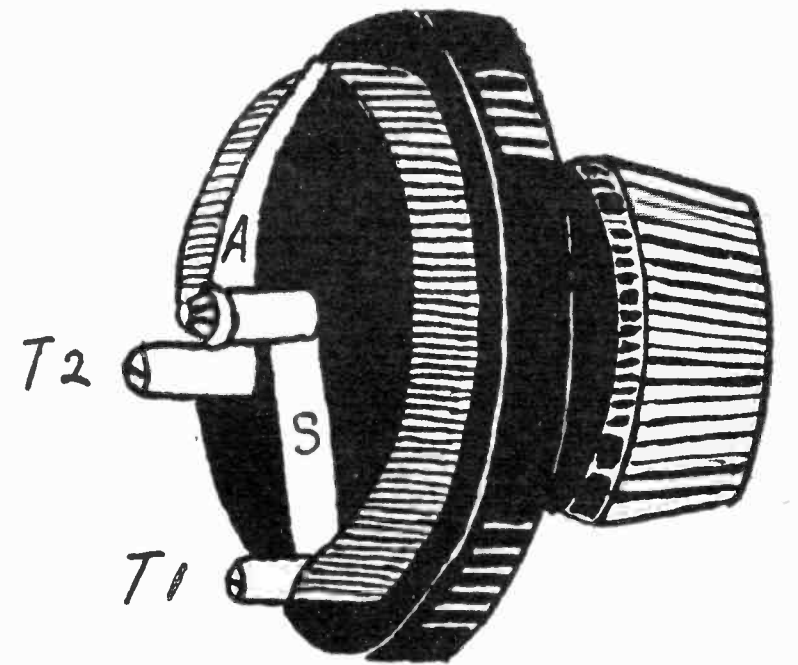

Fig. 3. Here is a Place Where High Resistance Wire is Needed.

foolish they are as it has considerably more resistance than copper.

At the other end of the scale we find nichrome, which has a resistance about sixty times as great as copper. That is one reason why it is so popular in rheostats. It is not injured by high temperatures. Another resistance material which is quite common is nickel silver, which used to be called German silver. This is not nearly as expensive as nichrome. A rheostat using one of these materials is employed in almost every tube set and is illustrated in Fig. 3. Here "S" is the strip connecting the binding post to terminal T1, while the resistance wire is wound from T2 on a fibre strip. Arm "A" rubs on the wire.

Wire for Ballast Coil

The material with the lowest temperature coefficient is manganin. This is used very extensively in making resistances in standard test instruments for the laboratory. It has the great advantage that, as it gets warmed up from the current passing through the wire, the resistance does not change materially. If iron wire had been used instead, its value would be shifting all the time with temperature. At the other end is nickel, which has the biggest temperature effect, and so is used in ballast coils to hold the current constant through the filament of a vacuum tube.

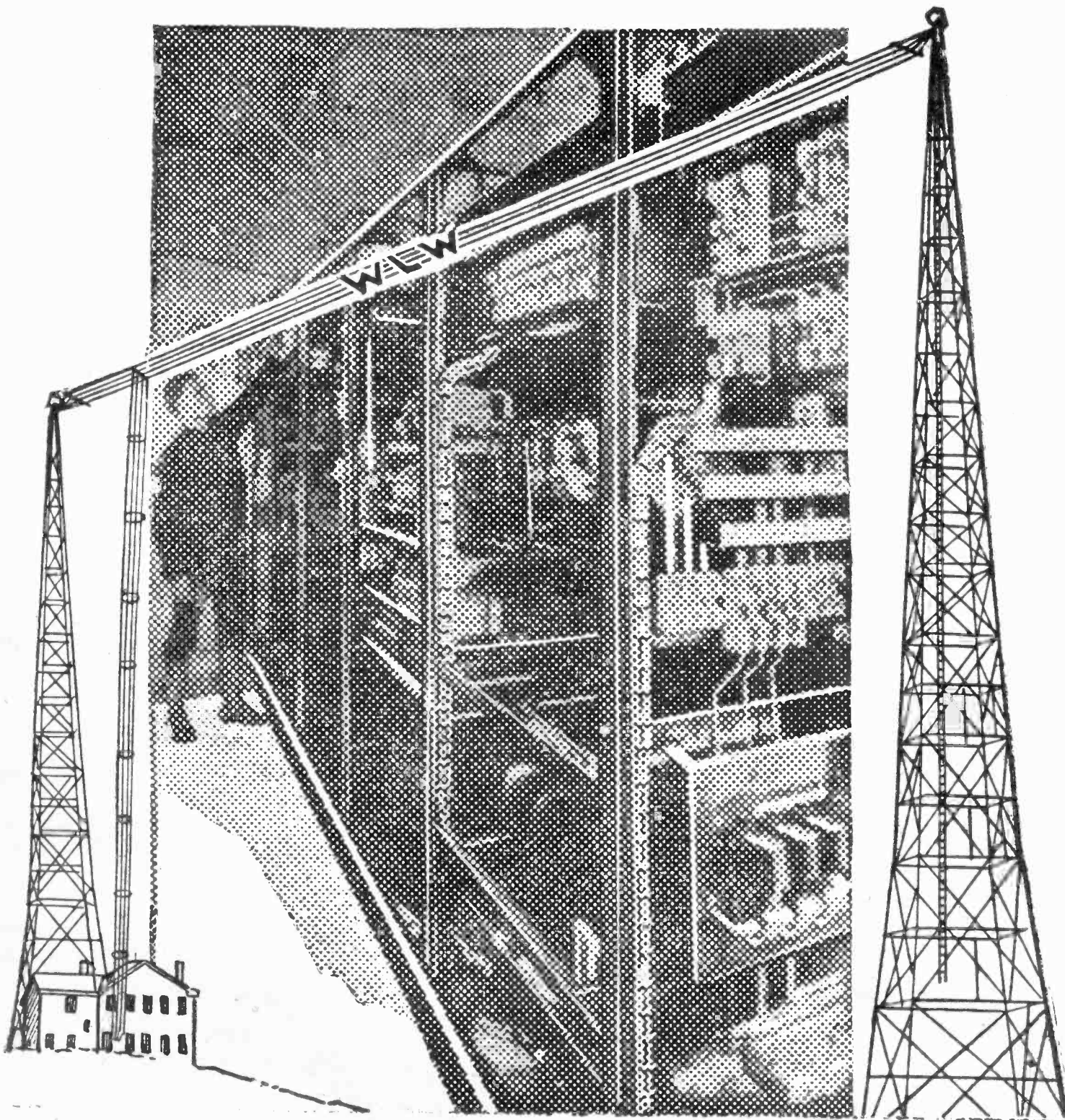

BEHIND THE SCENES

Perhaps you carried a portable set around with you this summer. Even a six-tube radio does not take up much space. On the other hand, the sending station with its large power is quite a sizeable proposition.

Here is a view of the power panels at the WLW Cincinnati sending station. This has a transmitter of five kilowatts which is the largest size permitted by the Department of Commerce for ordinary broadcasting. It is located 25 miles away from its control studio.

Some Tests On Signal Strength

Checking Up on the Radio Waves in the Air

An Interview from the Department of Commerce, Washington

HOW far can you hear with your radio set? This depends a great deal on your location as well as on the receiver itself.

Naturally a loud noise is heard much farther than a faint one. A whisper may not carry across the room, while

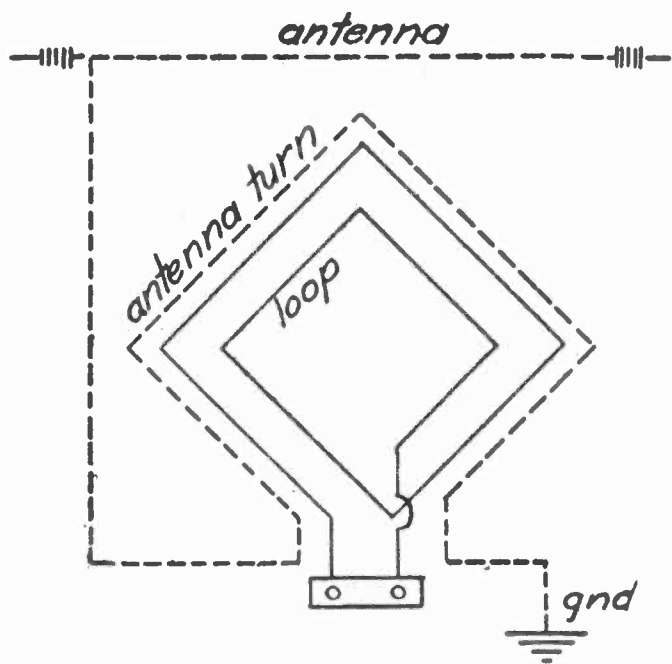

Fig. 1. By Combining Loop and Short Antenna, One Way Only is Picked Up.

when your neighbors are quarreling they may be heard a block. In the same way a 50-watt station does not carry more than a fraction as far as a 500-watter.

Treat Them All Alike

In order to compare radio sets with some degree of accuracy, it is necessary that you supply similar amounts of energy to the aerial post. If you are testing right along at the same laboratory, then the aerial itself will be impartial and not treat one set better than another. However, it often happens that you listen to your set at home and then your friend's set in another part of the town. Perhaps your antenna is much better insulated and higher than his. If so, it is not fair to condemn his set because it does not reach out as far as yours.

But even on the same aerial different stations naturally come in with very different amounts of power. This is

partly due to the different sizes of the transmitters and also to the various distances which the waves must travel before reaching your house. The surroundings often have a very great effect, too, in the loudness of the programs you receive. You will not expect to get as good results when near a steel sky scraper as you will out in the country.

Through the Air or Ether

The Department of Commerce has recently been doing considerable experimenting to determine what signal strength is coming through the air itself at different points. By "air" we do not mean the actual gases of our atmosphere, but use the word in the usual sense. Strictly speaking, the radio waves are supposed to be carried by the ether. The idea of the measurements is to find out how much steel buildings, trees, trolley wires and the like weaken the waves, and also to determine the

field is produced in California by slow wave (long wave length) high-power radio stations on the other side of the Pacific. For this purpose, measurements were made by Dr. L. W. Austin of the Bureau of Standards in San Diego on the arc stations at Cavite, Philippine Islands, and Malabar, Java, which lie respectively about 7,500 miles and 9,400 miles from San Diego. These are about the greatest transmission distances attainable by daylight over water with the present high-power stations.

Keeping the Locals Away

The signals were measured by comparing them in the telephones with signals from a local sender of known strength. To keep out interference from the Eastern stations and to reduce static, it was generally necessary to receive the signal on a unidirectional antenna and coil combination.

This idea is indicated in Fig. 1. We

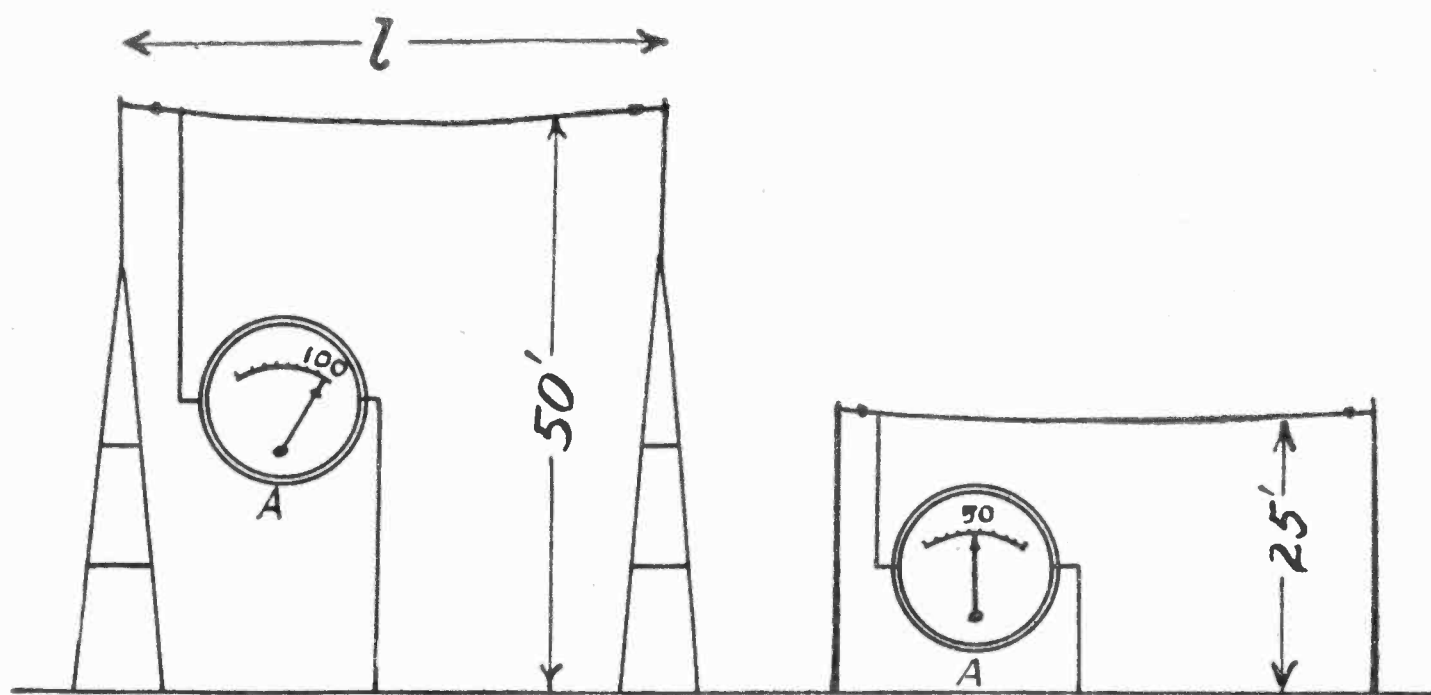

Fig. 2. The Electric Field on Signal Strength is Same at Both Antennas, Although of Different Heights.

apparent direction from which the vibrations come.

The Transmission Research Laboratory, conducted jointly by the Bureau of Standards and the American section of the International Union for Scientific Radiotelegraphy, has been investigating the question as to how strong an electric

have an ordinary loop with two terminals on the terminal board as shown. Such a loop as is well known is quite directional. Stations that lie either to the right or the left of the loop as it appears in the cut will be heard with full intensity. That is because the ether vibrations strike first one side and then

the other side of the loop. It is this slight difference in timing which makes this form of aerial pick up the wave.

Then the Loop is Silent

When the station lies in front or behind the loop then the oscillations reach all the wires at the same instant, and so there is no difference in timing at all. As a result the loop will not bring in any station along its axis. When the sending aerial lies at an angle somewhere between the two which have just been discussed, then the loudness of the signal will not be as great as the maximum, but can be heard to some extent.

Notice that such a loop will pick up a station at the *right* or the *left* equally well. If we wish to hear only the sender

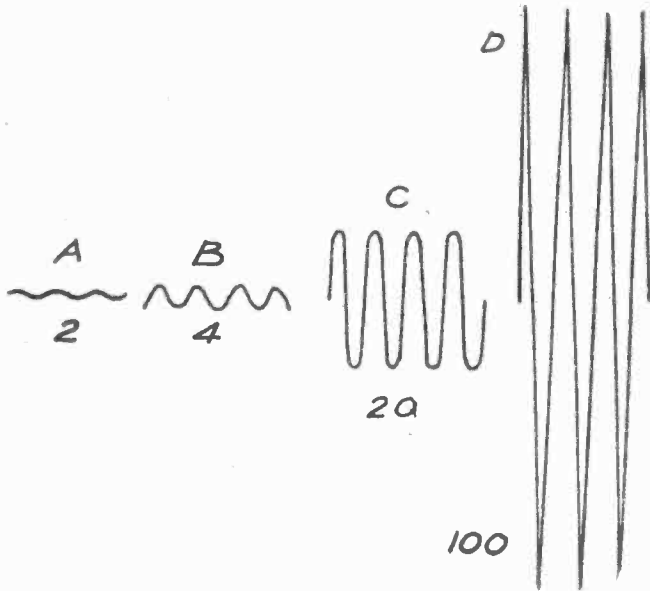

Fig. 3. The First Two Waves Were Picked Up on Pacific Coast; Others On Atlantic.

at the left, then we must do something to cut out the other fellow. This may be accomplished by adding a short antenna and turn as illustrated. Such an aerial will be practically non-directional, especially if the flat top is kept small. It will add to the left hand station and subtract from the right hand or the converse, depending on which direction the coil is wound.

Gets Rid of Other Point

By adjusting the height of the outside antenna and the number of turns it is possible to make the effect from the loop just equal to that of the antenna. In such a case the two will add to double the strength at say the left, while they will subtract and so just cancel each other at the right. Of course, by turning the aerial around, this directional effect will be reversed. Such a combined aerial will be directional, but it will receive best from only *one* point of the compass instead of from two.

Of course, determinations on signal

strength are very delicate and cannot be rushed. However, on account of the great difference in time between San Diego and Cavite (8 hours), and Malabar (9 hours), it was possible to observe only about two hours of the day without getting too near sunrise or sunset at either the sending or receiving stations.

Almost 600 Miles Apart

In measuring the strength of the radio waves as they strike your aerial the unit is called "microvolts per meter." The meter you will recall is slightly over a yard long and a microvolt is one millionth ($1/1,000,000$) of a volt. If you had two wires with an old dry cell (which had a pressure of only one volt) connected to them, then the ends would have to be spaced a million meters (600 miles) apart to give this amount of field strength.

The reason that the measurement is made *per meter* is this: A high aerial picks up more energy than a low one and it is found that the intensity varies directly as the height of the antenna. Thus in Figure 2 the aerial at the left is 50 feet high while that at the right is 25. Suppose the sending station whose wave we are measuring is just strong enough so that the meter at the left reads 100 microvolts. Then the right hand meter at the same locality will point to 50 on its scale, since its aerial is only half as high.

No One Mentions Length

Of course in actual test the meters are not connected directly between the aerial and ground as illustrated in our cut, but to a special receiving set. This is not shown so as to bring out the idea of the height better. Notice that nothing is said about the *length* of the flat top of the aerial. This measurement effects the capacity and tuning but does not change the reading of the meter when the instrument is properly tuned.

In the left hand case which has just been described the field strength is found by dividing the microvolts shown on the voltmeter by the height. This will be 100 divided by 50 or two microvolts per foot. In the right hand case it is 50 divided by 25 or again 2. Naturally the answer should be the same in both cases since both installations are made at the same place and the field strength through the air has nothing to do with the kind of aerial which is erected. A strength

of two microvolts per foot is equal to slightly over six microvolts per meter.

Ears Good in California

The average field intensity produced by Cavite was 2.04, and Malabar 4.02 microvolts per meter. These received signals are very feeble compared with those picked up in Transatlantic radio communication which generally vary between 20 and more than 100 microvolts per meter. That Cavite and Malabar can carry on successful communication to California shows the excellence of the receiving conditions there.

To get some idea of how feeble these waves are, look at Fig. 3. Here are four sets of waves with different heights or amplitude. The first one at A is

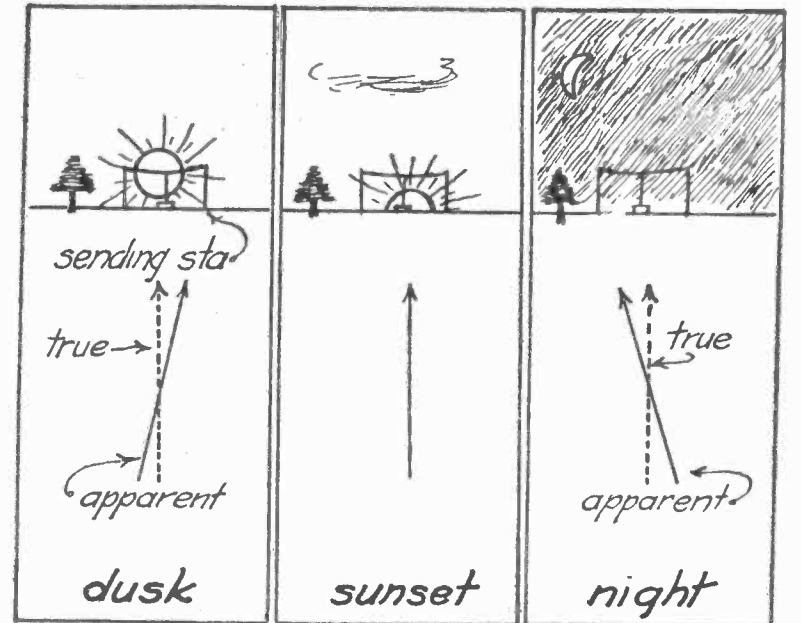

Fig. 4. This Shows Strange Shift in Direction of Broadcast Waves.

$2/64$ of an inch high which represents the two microvolts per meter from Cavite. The second one, at B, is $4/64$, which illustrates the value from Malabar. At C and D are waves 20 and $100/64$ ths high which shows the range of the ordinary signals picked up on the Atlantic Coast. By comparing these oscillations you will see how fortunate the Western Coast is compared with the Eastern in its ability to hear feeble signals without too much interference from static.

Same in U. S. as France

Dr. L. W. Austin has recently been making measurements on waves coming from the east. Tests show that the average intensity of signals from European and California stations were somewhat less during 1924 than in 1923. The *variations* of the intensity of received signals from the high power station at Bordeaux, France, have been found to be the same in France and in the United States, whereas no such correspondence in the received signals is found for measurements in the two countries on the

transmitted waves from the high power station at Rocky Point, Long Island.

That is, suppose that on, say, a certain Tuesday night the waves from Bordeaux as picked up in Paris were only half as powerful as those of the preceding Monday. Then measurements in the United States on the same days showed a similar falling off. But when the signals started at Rocky Point, L. I., the two countries would not experience a falling off in audibility on the same days. This would seem to indicate that the source of variation must lie near Bordeaux so that waves in all directions were equally affected.

Better by Day Than Night

In measurements on the strength of signals from European stations there is found a drop in received power just after the time of sunset in Europe. Observations of signals from high power stations over greater distances than have been before attempted, as for example from Java to California, showed that the low-frequency stations transmitted to greater distances than calculations had indicated. Measurements at frequencies above 3,000 kilocycles (100 meters) indicate that the fading of such signals is greater, and the reliability of transmission less, at distances under 500 miles than at greater distances. Furthermore, in the winter frequencies above 5,000 kilocycles (60 meters) are observed to be transmitted much better in the daytime than at night, this being the reverse of conditions with lower frequencies.

Dr. A. H. Taylor has been working with the radio compass. He has found that a shift of the apparent direction of the waves from slow wave stations occurs at sunset. The direction shifts towards the east before sunset, returns to normal as the sun goes down, and then usually shifts to the west.

It Changes at Sunset

This is clearer from Fig. 4. Let us assume that sunset occurs about 7 o'clock. The station that we are picking up may lie due north of us. Then at 6:45 the incoming waves as revealed by a loop aerial will not be from the north but from some point north by east. A little later the sun goes down. Now the radio compass which is showing the direction from which it picks up the waves will point directly at the sending aerial, in this case due north. At about quarter or half past seven the apparent direction of the broadcast station will lie north by west.

The exact cause of this has not yet been fully determined but further experimental studies indicate that there is a combination of waves along the earth with waves reaching the receiving direction finder from a number of paths overhead, the whole effect being brought about by the change of ionization of the atmosphere as the sun sets. Some variations of direction of broadcast station transmission have been found at night. At very high frequencies the changes are very rapid and very great so that direction measurements are quite impossible.

They Follow the Clouds

Dr. Taylor also found that measurements of atmospheric disturbances produced in low-frequency receiving circuits during the last three years indicate that their intensity was greatest in 1922 and least in 1923. Observations of atmospheric disturbances indicate that their direction often corresponds accurately to the position of storm and cloud areas over

the country. At frequencies of more than 3,000 kilocycles (100 meters) atmospheric disturbances are comparatively mild in the daytime but at night in the summertime they are by no means negligible.

In order to make measurements of wave strengths in the air it has been necessary in the past to use very elaborate and delicate instruments. However, Mr. E. F. W. Alexanderson has recently reported that a committee who have been investigating the measurement of interfering radiation now have developed a portable direct-reading instrument for field strength measurements. This instrument will make it possible to determine the precise amount of interference not only on the main wave of a station but in the side bands and harmonics. The use of a standardized direct-reading instrument of this kind will make it possible to obtain actual statistical data on interference produced by various radio stations and other sources.



BROADCASTING A BEEF STEAK

Ragouts by radio are a daily happening from station KYW, Chicago. It was several years ago that this station started transmitting its "Table Talks" every morning at 11:35.

Mrs. Anna J. Peterson, who is on our left, was probably the first radio cook in the world. She is still the head of this department and has an able assistant in Miss Vivette Corman. Many a worrying housewife tunes in to this station to get a suggestion for what to eat for the next meal.

American Radio Relay League

THIRD CONVENTION GREAT SUCCESS

Report on Meeting of Amateurs in Chicago Hotel.

Radio interference, the development and use of the radio vacuum tube, and design of radio receivers were some of the subjects touched upon in the sessions of the Third National Convention of the American Radio Relay League at the Edgewater Beach Hotel in Chicago. Famous men in each of three divisions of radio science presented papers of interest to the several hundred transmitting radio amateurs attending the gathering.

Professor W. J. Williams of Rensselaer Polytechnic Institute and director of radio broadcasting station WHAZ of Troy, N. Y., covered the information now available about the various types of radio interference. He told of his experiences with power, telephone and telegraph companies in attempting to run down radio interference and pointed out some of the difficulties experienced with electrical appliances and vehicles, such as trolley cars and electric railroads.

Tubes Will be Standardized

J. C. Warner, who addressed the convention on the subject of vacuum tubes, has had a distinguished career as a radio engineer. Beginning his work on radio while a member of the faculty of the University of Kansas, he was ready for action at the outbreak of the war. Shortly after his entrance into the army signal corps he sailed for France and was assigned to work at the French Army Signal School at the Eiffel Tower, at that time one of the outstanding radio investigating agencies in the world. After the war he was connected with the Bureau of Standards for a time and from there he went to the General Electric Company, in charge of small tube development. His close connection with this work during practically all of the time that tubes have been undergoing so many refinements makes him a real authority on all phases of tube use and development.

The "Low Loss" Expert

Karl E. Hassel contributed much to

radio science when his theories crystallized the sentiment which led to such rapid development of low loss receiving apparatus. His address on receiver design follows years of close study of the vagaries of receivers in practice, and a clear understanding of the needs for more efficient operation.

Mr. Warner, now in charge of small tube development at the General Electric Company Research Laboratory, drew upon his store of experience gathered in the years during which vacuum tubes have made such tremendous strides. He announced the completion of work tending toward standardizing tube bases and sockets.

Your Friend Will Thank You

When you finish reading this magazine, don't throw it away. Just hand it to your friend. Any intelligent person can understand it, and your friend will thank you.

The demand for a dry battery tube that will supply sufficient undistorted audio frequency to operate a large loud speaker has been met, Mr. Warner said. He described another new tube which has such a large output that its use in sending is possible.

Full and Half Wave

Mr. Warner also discussed the development of two new alternating current tubes for use as components of "B" battery eliminators. One of these is a full wave rectifier and the other a half wave rectifier. The latter tubes may be used in pairs for a full wave connection, he said.

Speaking on the general subject of "Ultra-high Frequency Transmission," Dr. A. Hoyt Taylor, United States Naval Physicist and superintendent of the Naval Research Laboratory at Bellevue, D. C., explained methods for attaining accuracy in transmitting waves through crystal control. The research along this line at the Naval laboratory has done much to clearing away one of the big bugbears of radio, the variation of send-

ing station waves which made reception difficult.

His discussion covered the preparation of crystals and the explanation of several simple circuits to be used as master oscillators controlled by the crystals.

All About the Fast Waves

His talk on fast wave propagation phenomena covered experiences and observations at the Naval laboratory on ranges and peculiarities of these high frequency waves. He followed this with a theoretical discussion of certain physical phenomena worked out by Dr. E. O. Hulburt and himself at the laboratory, pointing out some of the causes underlying the results.

Speaking on the subject of "Efficiency in Transmission," John H. Miller, electrical engineer in charge of radio instrument development for the Jewel Electrical Instrument Company, pointed out the needs for greater distance in radio transmission using much less power than is now the vogue. He explained the methods in use for attaining distance and voiced the fear that continued use of high powered stations would remove much of the attraction from radio transmission. He pleaded for the use of highly efficient transmitters that might be operated on the most "miles per watt" basis.

Watch for the Prize

To add interest to the proceedings, Mr. Miller on behalf of the Jewell Company announced a contest for all members of the American Radio Relay League in which stations would compete for the record of most "miles per watt." A twenty-one jewel watch with hand engraved case will be the prize for the member station winning the contest. One other condition is that the greatest distance must be attained at least three times during the year in which the contest runs.



Mailing Lists

Will help you increase sales
Send for FREE catalog giving counts
and prices on thousands of classified
names of your best prospective customers—
National, State and Local—Individuals,
Professions, Business Concerns.

99% Guaranteed 5¢ each
by refund of

ROSS-Gould Co. 6128. 10th St. St. Louis

Give That Smart Look to Your Panel

Fashions in Sets Which Look and Work Well

By STUART STANDIFORD, Youngstown, Ohio

WHAT a beautiful radio," exclaims the sweet young thing, as she gazes at the wonderful piece of furniture displayed in the salesroom.

Perhaps, however, the set in question may have a harsh tone and will not pick a station more than a few hundred miles away even on a good night. Indeed many of the radio companies seem to be turning most of their attention now to the appearance rather than the performance of their sets.

What Kind of a Circuit?

One company recently put out a sales leaflet on their receivers which in the paragraph labelled "Specifications" had a description of the color and finish of the cabinet and the weight and price of the set but no mention was made of the kind of circuit or even the number of tubes. However, a radio may be made which is very efficient and yet has the fine appearance of an elegant piece of furniture.

It is of the utmost importance in radio broadcast reception, that all parts of a receiving set should work at their greatest possible efficiency, in order that the waves sent out from distant broadcasting stations should be heard to their loudest extent. The more sensitive any outfit is, the better it will perform in long distance reception which is so much desired by radio fans nowadays.

Where the Trouble Lies

Owing to the lower efficiency in our outfits as contrasted to what they may possibly be in years to come, we have to take advantage of every little thing which will enable us to obtain selectivity, clearness of programs and also loudness of signals; these should be combined with ease of operation. The great difficulty in all sets of whatever construction at the present time, exists in the small amount of electrical power which is picked up by the antenna.

On this account, we must construct all

parts, such as coils, transformers, condensers, wire joints, etc., in such a way that they will have the lowest possible resistance that can be obtained. The insulation should be as perfect as we can make it so as to prevent energy losses in that direction. It is characteristic of electricity that it will take short cuts from wire to wire in any set wherever bare wires may touch. This applies equally well to the low voltage, high frequency waves picked up by receiving sets. When it is remembered that this

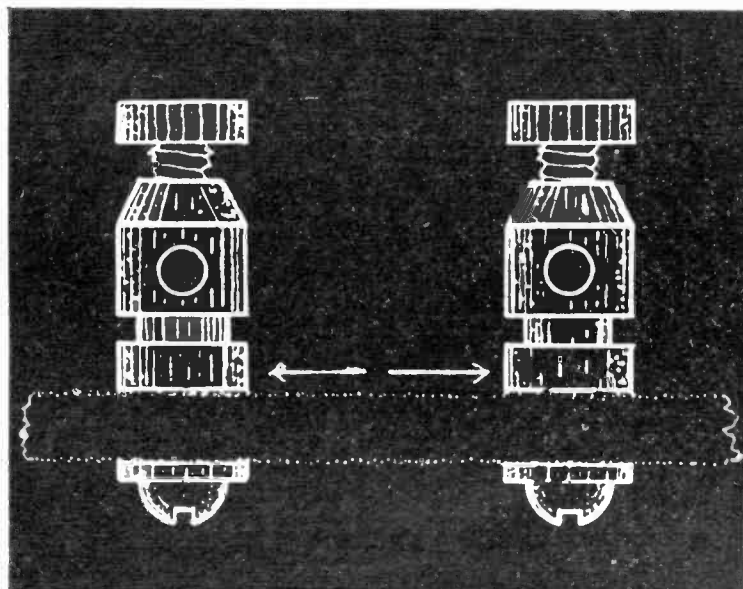

Fig. 1. The Arrows Show How High Frequency Alternating Currents Leak.

tiny amount of current from a distant station, after going through the proper instruments, finally emerges in such volume as to be heard all over a large-sized room, it will readily be realized that a receiver has to be in good condition to produce such a result.

Do You Like Dull Finish?

If any part of a set should happen to allow these low voltage and high frequency waves to leak from one part to another then the sensitivity of each part will be lessened. This in turn shortens reception distance, besides adding other difficulties that will cause a radio novice much worry. The condition of your panel plays an important part in helping to secure fine results. Many amateur constructors prefer a dull-finished panel to one having a glossy surface, as

they think that it makes a better appearance, which I agree with, as far as looks go.

I have found out though that it is something more than a mere matter of taste; a dull surface panel is not nearly as efficient as a glossy one. As many panels sold on the market are glossy, the first thing many builders do, is to roughen its surface with fine sandpaper, finishing up with pumice stone and oil so as to get a finish showing a small grain, or in other words, a dull finish. Examined under a magnifying glass of low power, it will be seen that the grain resembles small hills spaced close together. Thus if in building a radio set you dull a panel's surface by using either sandpaper, emery cloth or other abrasive, you very greatly increase the area of the panel's surface and provide many small cavities in which grime and dust may lodge.

And furthermore, when you use pumice stone and oil for finishing work you are in reality, doing your best to cause the ever-present dust particles floating in the air to settle on the panel and fill the small pockets you have already placed there by your treatment of the material. Another thing—a roughened surface is always more or less porous. This condition allows moisture to collect in the pores and dust will stick to it, forming an attractive path from one binding post to another for radio frequency current to follow.

Fig. 1 illustrates how leakage can occur between binding posts and other parts of a radio receiver when a rough surfaced panel is used. Dust gets in between the little hills and makes a good path for the high frequency currents between various parts. Roughness of the panel is purposely exaggerated in the sketch, but the leakage may occur to a more or less extent with all rough panels. Broadcast current being very weak in any set, owing to distance the

waves have travelled, it is best to use smooth panels so as to obtain the utmost efficiency in long-range reception. Arrows between binding posts show how dust makes it easier for electric current to take a short cut, instead of going through the various instruments contained in the cabinet.

Both Sides to be Alike

In order effectively to keep down all electrical losses to a minimum, it is essential that *both* sides or surfaces of a panel be smooth. A glossy finish should also be applied to sub panels or any other material upon which tuning instruments or sockets are to be placed. The use of mahogany finished panels made of hard-rubber, bakelite, formica or other phenol compounds on radio sets, is rapidly increasing in popularity. This is due not only to their fine appearance when fitted to a cabinet of high-grade mahogany colored woodwork, but also to their efficiency and good qualities such as high dielectric strength, freedom from softening and warping by heat, and also of importance, the material won't discolor by the action of sunlight. It will not absorb moisture, and weather conditions have no effect upon its beautiful finish.

An interesting case came to my attention some time ago. An amateur radio fan painted a panel in his receiver, mahogany color so as to make it match the cabinet. Upon tuning in for long distance stations he discovered that the paint cut down the reception range to 65 miles, also making the signals inferior in quality. As most paint contains lead, which is a conductor of electricity, it acted as a partial short circuit and thus reduced the distance it would pick up. That novice learned by experience that insulation is a big factor and plays an important part in radio work.

When You Buy New Set

As there seems to be some confusion in the minds of new radio enthusiasts who are considering buying a set, as to what constitutes a good radio outfit and what it will do, the following pointers will give an idea in regard to the qualities which a well insulated and carefully made receiver should have. While radio today will probably continue to be improved on, still it has reached a stage of marvelous efficiency considering the short time it has been in existence.

A fine set should give the reception of instrumental music and the human voice, correctly modulated, undistorted and with the greatest fidelity to the original sounds; it will always cover reasonably great distances, and occasionally have an unusually great range. A good receiver ought to be simple to operate and "fool-proof," be well constructed electrically and mechanically. It should have a high degree of selectivity, which means its ability to tune out local broadcasting and obtain outside stations while the local one is in operation. The possibility of logging stations is another important asset; thus it enables a person to keep a record and turn knobs and dials instantly to the point that will

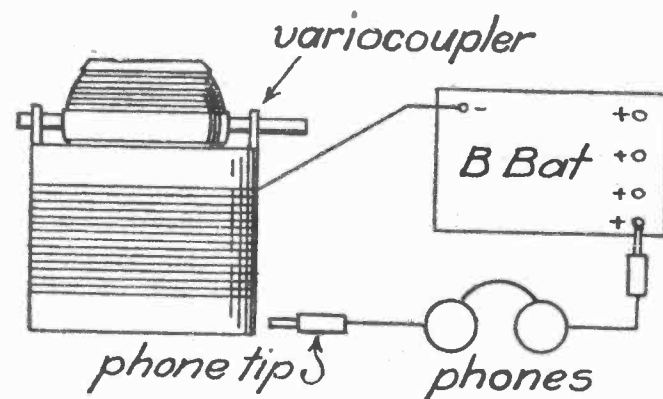

Fig. 2. How to Test an Instrument for Leakage.

give you the station whose broadcasting you wish to hear. This saves time and is a great convenience to a radio fan.

Will Your Set Do This?

Another important factor in a set, is its ability to work without interference (by radiation) to other listeners-in. It also should give loud speaker volume any time you want it on any class B broadcasting station within a few hundred miles. The question arises, can you actually find all of these qualities in a radio receiver at the present stage of the art? The answer is yes—unless you are seeking utter perfection, which does not exist at present. It is not too much to say that you most certainly can find them in the best outfits. By painstaking research, by a process of careful choosing and frequent elimination, manufacturers have brought radio outfits down to a point where they can be trusted, and they are making minor improvements all the time.

There is one thing equally certain; no receiver made by the average amateur and constructed of *cheap* parts, can compare with those made by manufacturers using high-grade parts, as the latter have all facilities for doing fine work

and being on a competitive basis with other manufacturers, they have to keep their product rigidly up to the highest notch of efficiency. This is the reason why amateurs "new to the game," are mostly buying partly assembled parts from a factory, paying a fair price for them and building good sets, as contrasted with what took place when broadcasting first began. Large numbers of factory made outfits ready to work are also being purchased.

How to Treat Wooden Parts

As a general rule, most novices who build their own receivers, do not see to it that the various parts in them are as well insulated as they should be. They will exert themselves to put all binding posts, connecting wires, etc., upon rubber or bakelite so that no contact is made with any material other than that of the panel. Then they consider that the best possible insulation has been obtained. Some tuning instruments, such as a wooden variometer and variocoupler with a wood rotor need attention. Naturally, if binding posts or clips for a variometer are screwed directly to the variometer woodwork, some energy loss may occur because of the moisture present in the pores of the wood. This is the reason why some variometers are poor in tuning. The wood employed in their construction has not been thoroughly dried, to drive out moisture.

It is a good policy for a radio fan to put new wooden variocouplers and the like in an oven for two hours to eliminate all moisture, and then give them two coats of shellac varnish, allowing the first one to dry thoroughly before putting on the other; this prevents any dampness from penetrating the wood. It will be found that this treatment will greatly improve the working of cheap wooden variometers and variocouplers, for those who happen to have them. By buying the best that the market affords, this trouble will not be necessary.

Testing for Trouble

If you are doubtful about any piece of apparatus in your stock you can easily test it for its insulating qualities as shown in Fig. 2. This may be a panel, condenser, transformer, variometer, or as shown here a variocoupler. In any of these instruments a small amount of leakage over the surface of

insulation not only wastes part of the received power coming in over your aerial, but also is quite apt to produce noise in your loud speaker.

To test for such a leakage all the apparatus you need is your "B" battery of 22 or 45 volts and a set of phones. A loud speaker would do in a pinch although of course, the headset is considerably more sensitive. Hook these units up as illustrated with one terminal (either positive or negative) connected to the instrument to be tested and the

other terminal of the "B" battery to your phones. The extra tip of the phones is to be used for exploring various parts of the insulation.

Listening for a Tap

While you listen in with the phones on your head tap with the phone tip along the edges of the insulation of the variocoupler. This action should not cause any clicking at all in the headset. Of course, you will hear the slight tap of the terminal itself but this is not at all electrical. If in doubt about it, discon-

nect the "B" battery and the tapping you now hear (if any) will be entirely mechanical. Naturally any effect must be caused by current running through the phones and therefore through or over the surface of the insulation. Any unit with such leakage should be condemned.

As an example of the use of such a test a certain set would not bring in any distance. The variocoupler was suspected and the above trial was made. A pronounced click was heard which located the trouble. It seems that the bakelite tube on which the wire was wound had been dyed black and that this therefore was a conductor. By using a different variocoupler the set was made to work correctly.

SPEEDY WAVES WIN CUP

Research work in wireless telegraphy was recognized at the 129th Commencement of Union College, when Edmund B. Redington of Waverly, New York, a Senior in the class of 1925, was awarded the Bailey Prize. This is a silver loving cup, and is given each year to the Senior who contributes most to the advancement of the college.

The particular bit of research for which the prize was awarded consisted of making a radio transmitter oscillate on the extremely high frequency of 80,000 kc. per second (3.8 meters.) This was accomplished while using standard equipment in the form of two 50-watt tubes. Previously oscillators had been made to operate on 70,000 kc., but until the Union College Radio Club developed this high speed wave oscillator, it had been necessary to dispense with the sockets and also to remove the tube bases. It had also been found essential to nullify the internal tube capacity. The oscillator devised at Union College, however, used this capacity instead of an external condenser, and by making extremely short connections between the tube sockets they were able to obtain an unusually high speed oscillatory circuit, which of course, results in a short wave length.

While a radio course is not a part of the curriculum of Union College, a widespread interest in radio research exists. The work of the radio club is fostered by the Electrical Engineering Department of the college.



HOW TO BE BEAUTIFUL

"Miss Atlantic City," otherwise known as Lee Bartlett, was recently elected as the representative of that great summer resort. She has been broadcasting her personality through the microphone of the municipal station WPG "World's Playground."

On behalf of the great annual pageant which started early in September, Miss Atlantic City told her radio audience that "The value of the pageant is an inspiration to the young women of to-day; to increase the loveliness of their face and form."

Don't Try to Beat the Patent Laws

Maybe You Are Infringing and Liable to a Fine

By LEO T. PARKER, Cincinnati, Ohio

MOST people think of the law as crystallized common sense. That is a pretty good way of regarding it at that. The trouble is that one man's common sense doesn't always check with the next one's.

That is why laws must be enacted and written down. And when it comes to patents there are three parties which have to be considered—the inventor, the manufacturer, and the user of an article. To some extent the interests of each of these conflicts with the others. In such a case it is much better to *know* what the statutes say rather than to guess

what you think ought to be the law.

Can't Make it for Yourself

Contrary to the belief of most people, any individual who makes a patented invention even for his own private and profitable use, is liable as an infringer, provided of course, that the builder resides in the United States and the article is patented in this country.

The patent laws are very explicit in this respect and read distinctly that a patentee is granted the *exclusive* right to make, sell and use his invention. Persons desiring to use a patented invention of any kind must therefore pay

for the privilege, whether the invention is constructed to sell for a profit or built solely to benefit the maker. A user of a patented invention purchased from a legitimate dealer, obviously pays the inventor's profit in the selling price which he pays for the article.

What Patents Are For

The United States patent laws were formulated with the purpose in view of creating an interest in persons possessed of inventive ability, in order that they should exert this faculty toward perfecting new and improved things, so that the general public and the United States as a whole might be benefitted. It is quite clear that no one will spend months or years of his time and energy and a lot of money besides to perfect some device if, when it is finished, anyone can copy it without making a suitable return to the inventor.

Many schemes have been hatched, without much success, to rob inventors of the just fruits of their labors, but the courts are now and always have been in favor of upholding the inventors' rights.

Parts Made in Different States

For example, not so long ago, persons living in different states each arranged to manufacture a separate part of a patented invention. These various parts were shipped into another state and assembled by another person into an infringing machine, but notwithstanding this obscurity, all of the persons involved in this conspiracy were held liable as co-infringers. Unscrupulous persons and firms who have practiced many similar and equally as clever schemes to avoid paying profits to inventors have been held liable by the United States courts for the sustained damages and profits and proportional to the aid rendered in perpetrating the infringing acts.

It is not only a violation of the patent laws to build and use a patented article yourself, but if after legitimately buying

Continued on Next Page

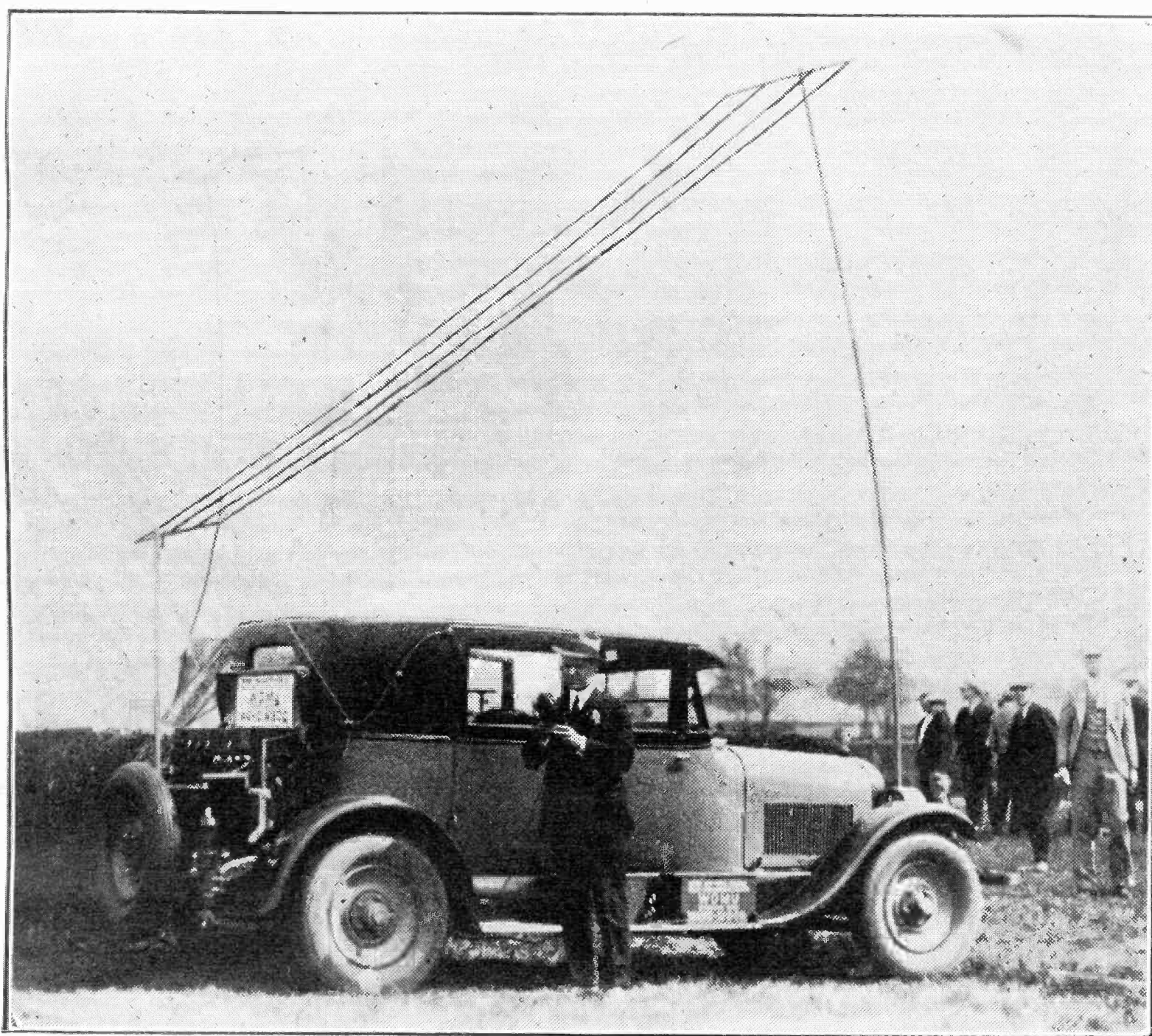

NO DETOUR FOR THIS AUTO

When you are travelling over the roads and come to a detour sign, you wish there were no such things. Here is a machine that takes the straight route as the crow flies.

We don't mean on its own wheels, but by radio waves. It is the portable broadcasting station, WGMU, of the Grebe Radio Company. At the mike you see Thornton Fisher, who has been doing some experimenting from this short aerial.

How the Navy Cut Out Static

Interesting Experiments on Reducing This Kind of Trouble

By C. WILLIAM RADOS, Arlington Heights, Mass.

NOW that the summer time is over you are probably heaving a sigh of relief at the thought that severe static will bother you no longer. However, even the fall has occasional days when the loud speaker seems to be announcing that you are putting in load after load of coal.

The U. S. Navy has been experimenting with ways and means of reducing this pest. Of course, the general trouble with static eliminators is that while they are quite successful in cutting out the interference they reduce the signal in about the same proportion. However, the Navy has got hold of two different schemes, each of which seems to discourage the static a lot more than it does the music.

Why the Dust Gathered

Many people this summer let the dust collect on their radio sets because they were out so much in the open air. That

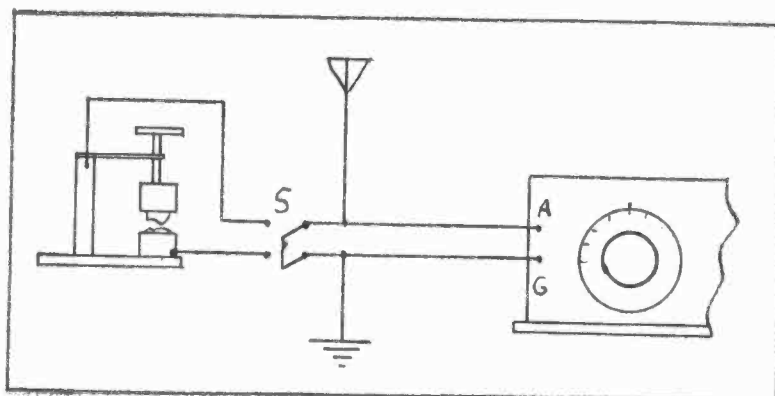

Fig. 1. This Crystal When Properly Adjusted Will Discourage Static.

is a very good reason for neglecting this useful instrument. Other fans signed off for a couple of months because they were afraid that static would spoil their

reception. That this was not necessary is shown by the thousands of people who have been listening in all summer and enjoying the radio. There have been many nights when there was very little static, and the Pacific Coast could be heard on powerful sets.

With a single tube, a short low aerial, and a two-coil tuner, the static will be greatly lessened, but, of course, the phones will have to be worn instead of listening to the loud speaker.

At the naval radio station, NAR, the following static eliminator was used for a time with remarkable results: A silicon antimony detector is made up as shown in Fig. 1. Any holder will do if the upper crystal is on a screw so

Continued on Next Page

DON'T BEAT LAWS

Continued from Previous Page

a device of this kind, it becomes so worn out in use that it is necessary completely to rebuild it, this remodelling process also is an infringement of the patent. A patentee, when he chooses to do so, instead of selling his patented article outright, may merely *license* its use so that a user is limited to the contract upon which the permitted employment of the article is extended. A patent gives its owner an absolute monopoly of the invention for a full 17-year term.

They Are Ignorant Offenders

It is true many persons construct patented articles for the purpose of avoiding paying the purchase price, and use them for their own personal benefit. A most remarkable and peculiar condition exists also, in that 90 per cent of this class of infringers are not aware of the committed offenses, because they honestly believe persons are privileged to make patented devices for their *own* use. It would be extremely surprising to many of them, however, if the

owners of the adjudicated patents were to obtain the required information of the identity of the various infringers and then institute legal proceedings to recover the justifiable damages and profits. This procedure has often been carried out by patentees in the past.

Here is an illustration. Several years ago, a certain automobile skid chain manufacturer became greatly irritated because retail dealers in certain parts of the country were accustomed to supply their customers with chain in the required lengths, whereby the automobile owners were enabled to make the patented skid chains for their own use at a considerable saving over the selling price of the patented product. So the infringed manufacturer started legal proceedings against various retail firms and individuals with the quick result that the retailers and users were stopped from the practice.

They Are Really Stealing It

Sometimes it is a very difficult matter for the owner of a patent to get enough information so that he is able to bring to court the people who are stealing his

patent. However, that does not alter the fact that anyone who copies such a device without paying any royalty is really robbing the owner of what belongs to him not only by law but by moral justice as well. Every inventor is entitled to a reasonable return as a royalty for the work he has done.

The radio industry, however, is one that owes its marvelously rapid progress at least to a great extent, to experiments that have been carried on by many different individuals. Most of them have been compelled to utilize some ideas and inventions that belong to other persons. This is true because to become familiar with radio apparatus the experimenter tries first one arrangement and then another, endeavoring to decide which circuit produces the strongest, clearest and most selective signals. In fact some of the largest manufacturers, engaged in making radio sets, have extended the free use of their patents to experimenters and persons building sets for their own individual use providing these persons employ certain specified equipment, as tubes, made and sold by the firm extending the privileges.

HOW NAVY CUT OUT STATIC

Continued from Previous Page
that it can be moved up and down. A crystal of silicon is attached to one cup, and one of antimony is fastened in the other cup.

Must Have a Fine Adjustment

As mentioned, the upper crystal must be supported by a screw so that it can be adjusted easily through a very small distance and yet, when once the proper position is found, it will not shift further. The reason for such a fine adjustment is that the pressure between the two surfaces has a very great effect on the resistance and also on the rectifying action of the device.

This detector, or static eliminator, is connected across the antenna and ground as shown in Fig. 1. If the antimony crystal is connected to antenna and the silicon to ground, the device will work correctly. A double pole, single throw switch, is used to connect the eliminator to the aerial, ground and receiving set. In the illustration no lightning arrester is indicated, but, of course, this and also an aerial grounding switch should be used.

Then the Static Fades Away

To operate this device, first tune in the station as usual, leaving switch, S, open. When the signal is strongest, close switch S, with the two crystals touching. Then vary the contact between them and at some particular point the static will be materially reduced, while the signal will suffer but little. Once it is adjusted, it is best to let the crystals alone and retune slightly at the receiving set.

The idea of this device is as follows: When the series of radio waves come into the aerial they are to some extent short circuited by the pair of crystals. However, not much of the signal escapes in this way for two reasons. In the first place the crystals have no tuning effect whatever, as there is no coil or condenser connected with them.

Besides this the crystal allows current to flow only one way and so an oscillation, which consists of a vibration back and forth, cannot pass. The first half way may get through, but the reverse impulse is blocked off. That is why when properly adjusted, the program diminishes in loudness only slightly.

Static is Not Tuned

With the static it is another matter.

This is not tuned to any special wave frequency and so the first reason mentioned above does not prevent the interference from draining directly to ground without going through the set.

Besides this, static is caused by electric charges in the air and these usually have a definite polarity without oscillating back and forth the way a signal does. That is why the charge from static is able to leak through the crystals direct to ground, and there is practically no tendency for the charge to try to get back again from the earth to the

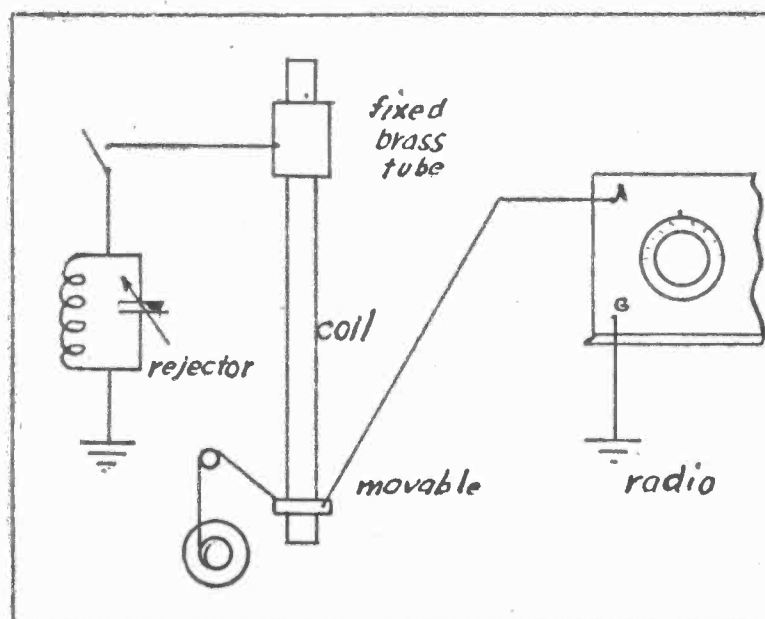

Fig. 2. The Sliding Coil in the Tube Short Circuits the Disturbance.

cloud. We thus have a one-way street, which allows one-way static to pass while it blocks the two-way radio traffic.

Oil Doesn't Smooth the Action

Of course, the crystals must both be kept clean. Do not touch the surface with your fingers as a slight film of the natural oil from your hand may be deposited with the result that current will not pass. Furthermore, when not using the eliminator, open switch S, as this will prevent the crystals being damaged by a heavy static discharge or stroke of lightning.

At NAR when static was so strong as to jump across a gap continuously, this device enabled the operators to carry on their work without any interruption due to this cause. This static eliminator is a sure thing when used with tube sets.

If you have a powerful set with three or more tubes you will be interested in a more elaborate device developed by the Navy to get rid of the troublesome atmospherics. It is called a "coil eliminator," and is shown in Fig. 2. The aerial is connected directly to the regular post of the set, but this is not shown in the illustration. In addition to the

aerial lead-in wire, hook up the lead to the movable coil as shown.

A Long Coil and Tube

This device consists of a long coil with a brass tube sliding over it as will be described shortly. This coil is connected to the aerial post so as to short circuit the static surges, which would otherwise interfere with your program. In series with the coil is a wave trap called a "rejector."

When a surge of static comes down the antenna in the average installation, it is transferred to the grid of the detector tube. This is what occurs in the single circuit tuner ordinarily. But now if we slide a brass tube over the coil and connect the brass tube to ground (Fig. 2) the static will not reach the receiving set. However, all other electrical disturbances, including signals as well, will be grounded also. What we want is a device to short circuit to ground all the static and power line hums, but to let the radio through clear and strong. If we can do this and at the same time cut out interfering stations, we shall have something worth while. That is what this device will do.

A 20-Inch Cardboard Tube

A coil and condenser connected between antenna and ground (Fig. 3) will, when tuned to a certain wave, let that wave speed through, but reject all others. All the other waves will go through to ground where they will bother no one. This device tunes sharply and is very valuable. For broadcast waves, 1500 to 500 kc., (200 to 600 meters) use a cardboard tube 3 inches diameter and 20 inches long.

Such a *series* wave trap is called an "acceptor" in distinction with the *parallel* or rejector trap. This series trap may be used ahead of the aerial post of the set where it will still further sharpen the tuning.

Getting now to the construction of the coil eliminator itself, we must build a coil with a brass tube sliding over it. Wind a single layer of No. 28 d.c.c. (double cotton covered) wire and do not use any shellac or other dope. Wind it on tightly and secure the ends by passing them through small holes in the tube. Then carefully place over the wire a layer of paper for the brass rings to slide on. Get a brass ring 1 inch wide and 3 3/16 inches diameter. Cut it with

Continued on Next Page

Broadcasting from the Polar Snows

How the Eskimos Sent Their Voices to the U. S.

By VANCE

DID it rain on your vacation? Perhaps you had wonderful weather or maybe the clouds and cold ruined your trip.

That is about what happened to MacMillan on his journey this summer into the far North. The cold held on so late into the spring that the ice had not melted away as it usually does even in the Polar Region. Because of this, he could not get his ship, the Bowdoin, and its companion, the "Peary," nearly as far North as he had expected.

Jagged Ice Stops Planes

Furthermore the unusually heavy winds had broken up the ice-floes

into such rough jagged masses that the air planes could not find very many places where they could land with safety. And to cap the climax the winter cold has already started in unusually early and so forced the expedition to start on its return.

In spite of these unusual handicaps the trip has added considerably to our useful knowledge of the Geography and natural conditions of the North. The experimental work done on fast wave (short wave length) transmitting and receiving has been very much worth while. An account of the broadcasting done to and from this polar expedition

will probably interest you.

Running All Summer

Every Wednesday at mid-night an unusual radio program has been sent from the Chicago Tribune broadcasting station, WGN, on the Drake Hotel, to the Bowdoin. The programs began on the day that Lieutenant Commander Donald MacMillan sailed from Boston—June 17, Bunker Hill Day—and will be continued until the return of his Arctic Exploring Expedition late this month. Commander MacMillan made a special request before sailing for the Arctic that his old friend and college fraternity brother, the Rev-

Continued on Next Page

HOW NAVY CUT OUT STATIC

Continued from Previous Page
a hack saw as shown, then solder a flexible lead to it and slip the ring over the coil, forcing if necessary.

Ring Runs on Pulley

Another brass tube 5 to 10 inches long and same diameter is needed. It is slipped over the other end of the coil and fastened there. A string is rigged up with a pulley arrangement, so that the small brass ring can be slid up and down. Arrange the string on a dial so that the ring can be returned to the same place each time, much as you log and set your condenser or variometer.

For the rejector you will need a good .0005 microfarad (mfd.) condenser. The coil (shown at extreme left of Fig. 2) is a three-inch tube with 60 turns of No. 24 dcc. It is better to locate this a few feet away from the wave trap apparatus. The idea is that the current in passing through the long coil will cause a magnetic flux or field to branch all around into the air, and if this field happens to cut the coil of the rejector, it will interfere and destroy the sharpness of its tuning. By locating the latter some distance away the magnetism from the long coil will be so very weak that it will not do any harm.

To operate this hook-up, first tune in your station as usual; then close the switch connecting the wave trap. When the latter is connected the station will

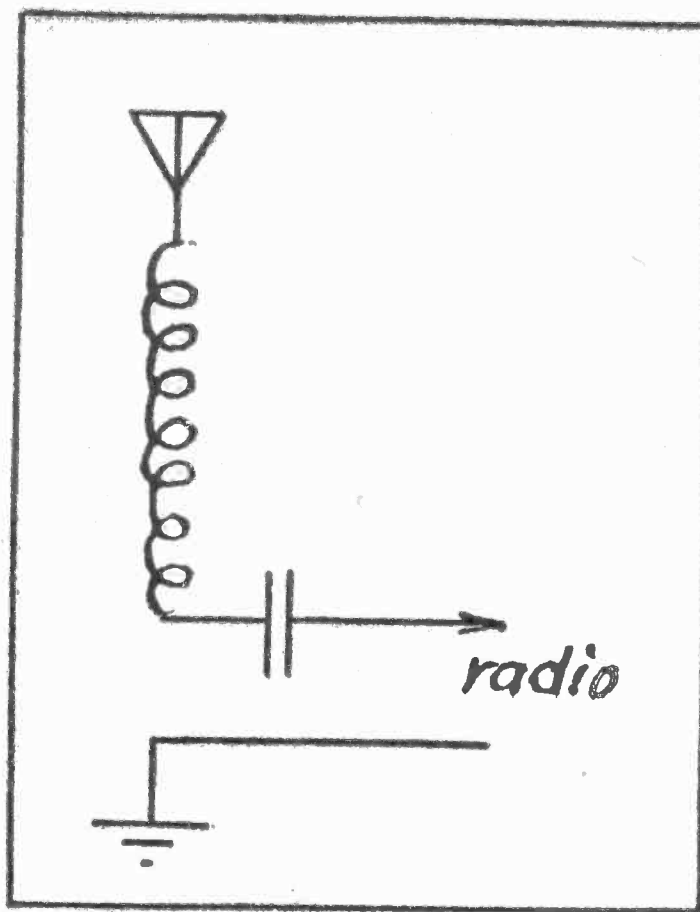

Fig. 3. This Acceptor Circuit Allows Only the Wanted Signal Through.

disappear. To get it back again without static or interference, the following method is used:

Leaving the movable coil at rest, slowly turn the rejector condenser throughout its entire scale. If the station is not heard, move the brass coil to a new position and try the rejector con-

denser again. At some adjustment of the two the signals will come in strong and clear without any interference. Even if you live as close as half a mile from a commercial station, this device will enable you to enjoy your radio in peace.

This device will give amazing results when you have had a little experience with it. Like all good things, however, we cannot get something for nothing. It must be handled carefully as it tunes very sharply. This, of course, is evidence that it works well, as a device which did not tune sharply would not be a good eliminator.

Hearing Through Static Wall

Most of the knowledge about these coils has been gained through the excellent work of our army and navy signal departments. They have been working on this problem a number of years. It may perhaps be still further improved. However, they have had exceptional results, being able to hear stations this way through static when it would be absolutely impossible by any ordinary method.

I would be glad to hear from any one constructing one of the above devices. Write to me at 16 Perth Road, Arlington Heights, Mass.

FROM THE POLAR SNOWS

Continued from Previous Page
erend Gardner MacWhorter of Chicago, should again give the same sort of weekly communication from home that he gave during the MacMillan Expedition of 1923-24.

The new Zenith broadcasting station, WJAZ, located at Mount Prospect, Illinois, some twenty odd miles out of Chicago, with the handsome Spanish studio on the twenty-third floor of the new Straus Building, Chicago, was not completed in time to carry on this unique broadcasting feature at first and the Chicago Tribune station was placed at the disposal of the Rev. MacWhorter in order that the weekly mid-night programs might be given. However, you may now hear "This is 9XN calling WNP," until the return of the Expedition. 9XN are the experimental call letters of Zenith Station WJAZ and WNP is Wireless North Pole, the station on board the schooner "Bowdoin," now on her third expedition into the Arctic.

This is a Good Program

The MacMillan programs are sent at mid-night, central standard time, and are usually of an hour or an hour and a half duration, consisting of several numbers of music given by friends who have volunteered for this personal service; then a short address by some close friend of Commander MacMillan who has frequently come from a distance to speak to the Commander, and the rest of the time is given over to the reading by the Rev. MacWhorter of personal messages from relatives of the men in the Arctic expedition's personnel, a comprehensive news digest of the world's events of greatest interest to the explorers, and an occasional humorous incident that may provoke a little laughter in the cabin of the "Bowdoin" or the S. S. "Peary," the sister ship of the "Bowdoin," under the direction of Lieutenant Commander Eugene F. McDonald, Jr.

These two heads of the expedition (MacMillan on our left) are seen in Fig. 1 on board the Peary. They both seem to be much interested in something overhead. However, it is not the mid-night sun which they are regarding, as they had not yet reached the Arctic Circle when this photograph was taken. The sending aerial is in this case the object of their attention. The insulation for

this antenna must be unusually good as the flying salt spray will freeze on the surface of everything it touches. For that reason it is necessary to employ strain insulators which are unusually long, to hold up the wires.

A List of Who's Who

During the past summer many distinguished guests have taken part in these programs from Chicago, including: Dean Paul Nixon of Bowdoin College, Maine, Commander MacMillan's Alma Mater; U. J. Herrmann, proprietor of the Cort Theatre, Chicago, manager of the New York and Chicago "Radio World's Fairs;" Mr. and Mrs. Frederick

On one Wednesday at mid-night, Commander McDonald's mother and sister came down to the Chicago Tribune broadcasting station on the Drake Hotel and spoke their greetings and good wishes to him. This reminds one of the occasion (Christmas Eve 1923) when Commander MacMillan's sister, Mrs. L. M. Fogg of Freeport, Maine, and his two nieces, the Misses Lillian and May Fogg, sent their greetings and good wishes to him from WJAZ. The most interesting part of the MacMillan programs to the Arctic from Chicago is their delightful informality, and while they are intended solely for the members of the MacMillan

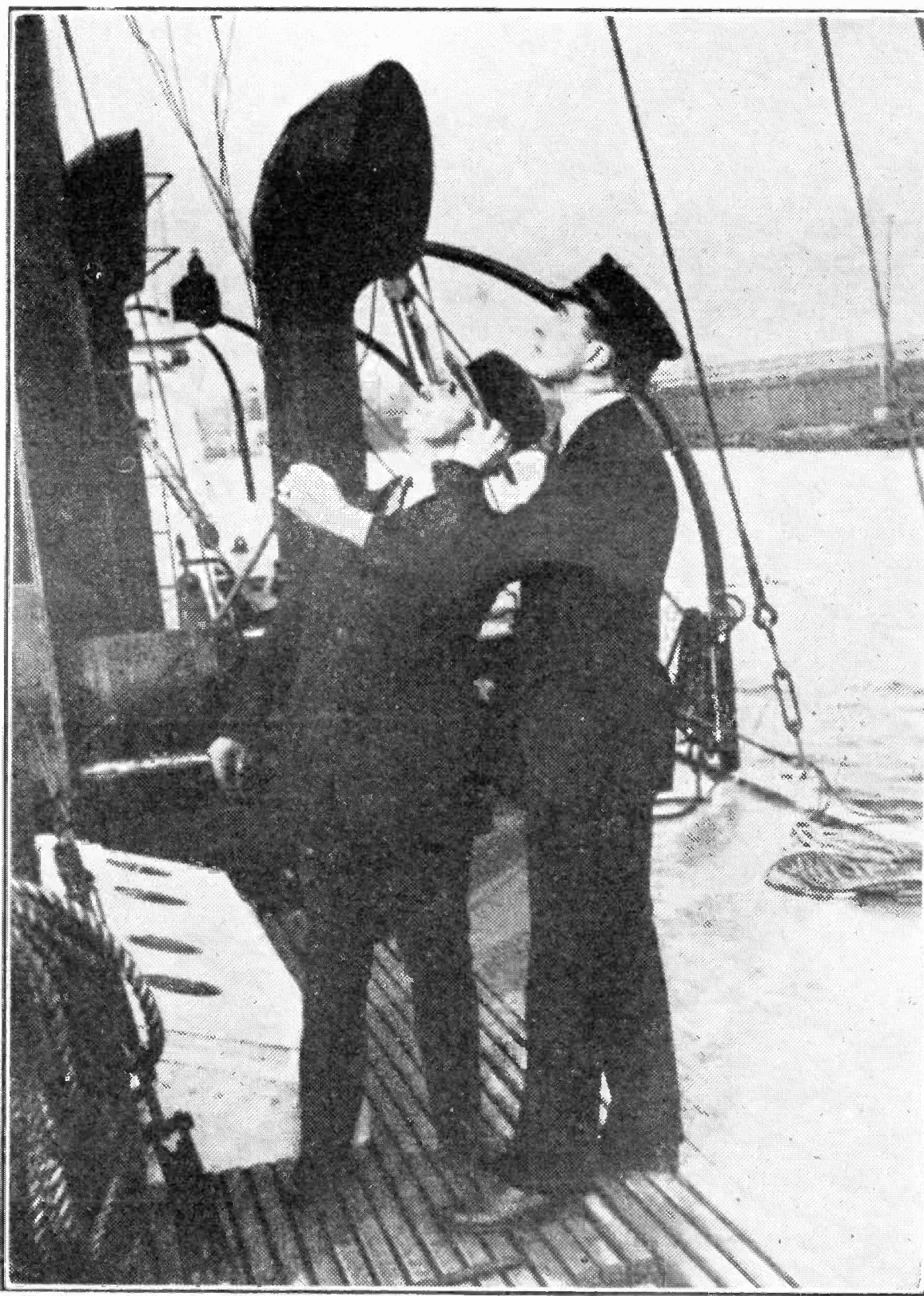

Fig. 1. Commanders MacMillan and McDonald Are Seen Inspecting the Aerial on Board the Peary.

H. Rawson of Chicago, parents of Kenneth Rawson, fourteen-year-old Cabin-boy of the "Bowdoin;" Mr. and Mrs. Elliott Jenkins, (Mrs. Jenkins being the former Alexandra Carlisle who placed Calvin Coolidge in nomination for the Presidency of the United States at the Republican National Convention in Chicago in 1920), and Jack Gregson, President of the Chicago Bowdoin College alumni.

Arctic Expedition, many thousands of radio enthusiasts interested in Commander MacMillan and his expedition have listened into these programs and sent word of their appreciation of them.

Why That Wave Was Picked

Of course the Chicago station transmitted at its usual frequency of 930 kc. (322 meters). The Bowdoin is equipped to transmit at ordinary broadcasting frequencies and in addition at 7,500 and

15,000 kc. (40 and 20 meters). Early in the journey it was found that the 7,500 kc. (40 meters) wave reached the United States through the 24-hour day light better than either the slower or faster vibrations. This was the wave selected by the Commander for doing practically all of his broadcasting.

Etah, Greenland, was the location at which a large part of the sending was done. The native Eskimos furnished most of the artists. Tu-nu-ka-ping-wa, the best hunter and the oldest kiloute player in the Arctic, and his gang, including In-you-gee-moo, who was with Peary; Kau-Gah and his tribe, the cliff dwellers of the Arctic; Au-kon-o-tes-wa, the oldest Eskimo in the tribe; Koo-e-teg-eto, son

tribes came into Etah, which was composed of only three families when the Bowdoin first landed. They said they wanted to see the "men who pass through the air like falcons—and faster."

Five Minutes to Crank Up

They brought their musical instruments with them, of which the kiloute seemed the most unique and interesting. The kiloute resembles a tennis racket, with the skin of the Walrus stretched across the frame, drum fashion, and bound together with sinews. It produces a weird drumming sound when beaten with a Walrus rib. The players roll their eyes and sway their bodies with rhythmic unison as all face each other in a circle. It takes them all of five

to be with their ability as singers and musicians. Their songs and their music they took very seriously, while all else in their lives is apparently nothing but happiness and laughter, — these most primitive people in all the world who live in holes in the ground and who were the most obliging and open-hearted people which MacMillan met in all his life.

But the audience back in civilization missed half the entertainment by being deprived of seeing them perform because they acted their songs as much as they sang them. If you can imagine it, the singers were dressed in seal skin robes, polar bear pants and seal skin or blue fox "netcha." Their program included "The Song of the Polar Bear," "The Song of the Fox" and "The Song of the Conboa," which all sounded alike to the white men, but each weird composition had a serious individual meaning to the performers.

In order to accomplish these results on this fast wave a lot of experimental work has to be done. 9XN rigged up an arrangement for relaying the Arctic concert by remote control to the new Zenith power station, WJAZ, who rebroadcast on 930 kc. (322 meters). This marked the first rebroadcast from the Arctic ever accomplished in the history of radio, and also was the first time that a concert or message sent out on a fast wave length was received, amplified and rebroadcast over a slower (longer) wave. The remarkable part of this test is the successful broadcast where broad daylight and sunshine prevail at the sending aerial. It is experiments like these that may lead to overcoming present day obstacles of weak signals during the day time, and which, if accomplished, will produce just as good reception in the light as we now enjoy in the hours of the night.

Different from Other Sets

The original transmitting apparatus on board the Bowdoin is not very different from other sending stations except for the compactness which is required by its location on ship board. A good view of the sending station in the cabin of this vessel is seen in Fig. 2. Commander MacMillan is shown at the operator's desk. The large heavy switches and coils belong to the transmitter, while the receiving apparatus you will notice resembles an ordinary radio set.

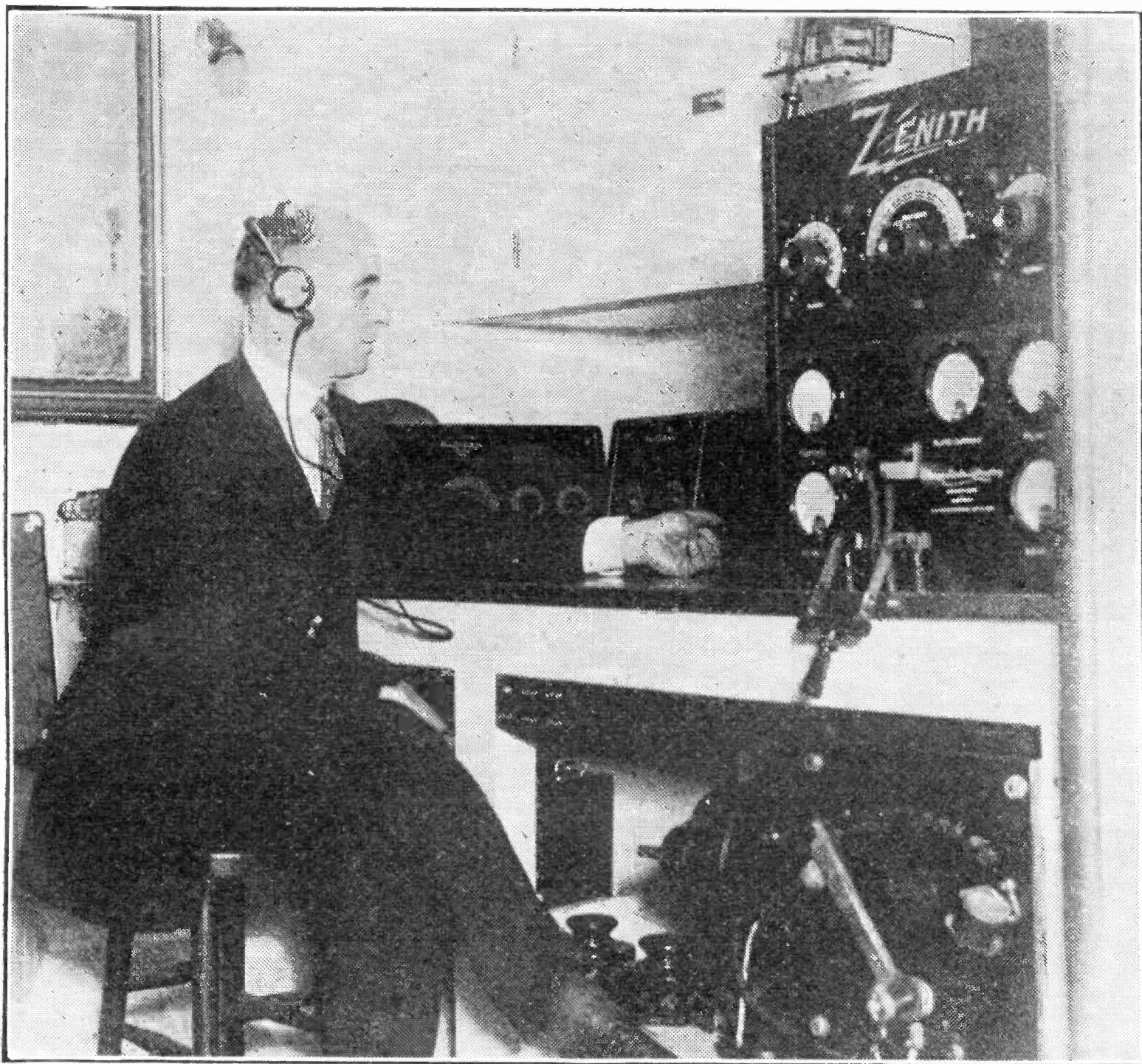

Fig. 2. MacMillan is Sending Out on 7,500 kc. (40 Meters) an Account of His Difficulties and Triumphs.

of Ootah, (who went with Peary to the pole) and Tow-Ching-Wa, son of Kau-gah, accompanied by other Eskimo men of the tribe, furnished both music and songs. Other natives of small villages for many miles around came in with their dog sleds after seeing the air planes making their test flights, and remembering MacMillan's promise last year that he would be back in Greenland "when the sun comes up again." Each day the population of the town increased as the

minutes to get warmed up and started for each number, and the starting process is not unlike static as heard in a radio. But you dare not laugh or they will stop playing instantly and run.

You can laugh when the song is finished, but not before, as the Eskimos seemed to take that as a form of applause rather than the audiences being amused by the humorous reaction they got. The harder the listeners laughed, the more satisfied the performers seemed

The high speed or frequency of the radio waves is gained by having the tuning coils and condensers of unusually small size. It is like a piano string—a low note or slow vibration is caused by a long heavy string, while a short light one means a fast oscillation. The switch which changes from sending to receiving will be noticed at the top of the photograph.

One of the pleasantest features of this

expedition. His latest accomplishment has been the successful transmission of voice and music to 2YI Australia. Many of the amateurs of New Zealand have heard the voice and music from the Peary. Lately he handled the message of Lieutenant Schnell from USS. "Seattle," lying off Wellington, N. Z., to the ARRL Convention in Chicago. In other words, in a period of a few minutes, while within twelve degrees of the

being questioned by Commander McDonald as to whether he would care to go to the Arctic, McGee, in true American form replied: "Yes, if my job will be waiting for me when I get back."

TRYING TO PLEASE YOU

The big broadcasting stations are certainly doing their best to give you highest class of service which they can possibly put out.

For instance, Station WIP, Gimbel Bros., Philadelphia, has announced the closing of their station from September 14 to 18, inclusive, so that they can install the latest improvements known to the art.

In particular they are changing over from their generators to a storage battery plant to furnish the necessary voltage to operate the filaments and plates of their sending tubes. If you have ever priced a storage "B" battery to work a receiving set you will know that it is quite expensive. When you consider that a *sending* tube requires thousands of volts on the plate and that the capacity in milliamperes must also be very much greater than your requirements, you will see why most stations have not yet gone to this expense.

The advantage of the storage battery over the generator is that the latter is apt to cause a slight hum owing to the fact that the current is lead out from the revolving armature by means of carbon brushes which bear against the commutator. This commutator is built up of hundreds of copper bars and as each one of these bars turns out from under the brush it causes a tiny ripple in the current, which you hear as a hum. Of course, this noise can be reduced to a very low value by using a filter but the best answer is the storage battery.

Station WIP will open its program again on September 19. When you listen in you will undoubtedly notice that the tone is smoother and clearer than ever before.

Making it Square

To square up the edge of a panel or any other piece of bakelite, use a common wood plane that has been set finely.



Fig. 3. Paul McGee Was the "Find" of the Party. He Proved to be an Exceptionally Good Operator.

trip has been the unusually brilliant work of Paul J. McGee, who started as the second radio operator. (Fig. 3).

Has Quite a Past Behind Him

As reward for faithful, loyal and efficient service he was recently advanced to the rank of Chief Radio Operator. His work has been consistent and he has cleared more than 75 per cent. of all messages sent by the expedition from the Arctic. The ingenuity and practical theory displayed by McGee has not been equaled by any other radio man of the

North Pole, he received from Schnell, far out in the South Pacific, less than fifty degrees from the South Pole, (nearly half way round the world) a message which he relayed to Chicago.

McGee is not a newcomer to radio as he ranks among the foremost pioneer radio amateurs, having secured his first license to operate station 9-A-E in the spring of 1914. In 1917 he enrolled in the U. S. N. R. F., where he served two years, and graduated from the famous "Harvard" Radio School, followed by eleven trips across the Atlantic. Upon



RADIO THE NEW DEB

The season is about opening when we shall have the flock of smiling debutants bursting forth upon an astonished world. Perhaps the first deb to make her bow is Radio.

The season is opening with a New York Show. Almost every fan all over the country has been waiting to see what was new in the art before deciding whether to purchase the latest model of his favorite set or to build the best fall hook-up, or perhaps if he finds no great changes to continue to use his old set.

No Revolution Here

In another column we have an account of some of the novelties on display at the show. As we have been predicting for the last few months, nothing revolutionary has appeared. This isn't very surprising when you consider what has happened at automobile shows. To be sure, the auto has been standard for a great deal longer than has the receiving set. But there is another factor to be considered.

In developing the motor car the only experimental work done that amounted to anything was performed in the research departments of the automobile factories. These were naturally few in number and required tremendous sums of money to carry on the work. After a change had been decided on it took a large amount of time before the necessary dies and tools could be made and very likely surrounding parts had to be adapted to fit the new devices.

Have You Helped?

It is quite different with this new development. There have been any number of experimenters at work among the radio

fans. Very likely you yourself have tried out one thing and another to see which one works better. When you multiply these home experiments by 500,000 or perhaps 1,000,000, you get some faint idea of the amount of development work going on *outside* the manufacturers' laboratories.

Besides this, a change once decided on can be made quite rapidly. If you alter the size or shape of your tuning condenser, that will not interfere with the location or dimensions of your transformers. A new socket does not conflict with a variocoupler, nor does the jack in any way depend on the grid leak.

A Rapid Climber

As the result of these two causes radio has reached its stable state in a fraction of the time it took the automobile to climb to its level. This does not mean that progress has stopped. It will continue for the next hundred years. But it will be mostly a matter of refinements and slight improvements. Of course, that does not mean that there will be no startling changes in the future. If they come, however, they will be few and far between.

THINKING IN MILLIONS

When we have a grid leak with a resistance of 3,000,000 ohms, that seems like quite a mouthful, and we prefer to call it three megohms. In that way it seems to be easier to grasp the idea.

In talking about the number of radio sets in the United States and the possibilities of still further increases we might perhaps use the same idea, as the figures are so large that they are hard to grasp and compare.

How Many Squeals?

The best estimates are fairly well agreed that at present there are about five million radios in this country. That seems quite a tremendous number to be squealing all at once. Or perhaps we should not say that, since more and more of the non-radiating types are being sold, and even the owners of the regenerative sets are getting to realize how they disturb their neighbors when they leave their tickler knobs turned on too far.

But if five million sets seems large, consider that there are about fifteen million passenger automobiles running over the roads in America. That makes three cars for every radio. This fact makes every store where receivers are sold feel a lot better, as it is certain that every one who owns a machine is a possible purchaser of a radio.

10,000,000 Must Walk

The United States census shows that the average family has about five persons, so there must be about twenty-two million families between Canada and Mexico. Since some families have two or more cars and some business concerns have fleets of them, there will be eight or ten million families who use the street cars to get down town. Surely there will be a large part of them who do not wish to invest the large amount of money necessary to buy an automobile but who can find the funds to get at least a one-tube radio.

Adding together the two classes which we have just mentioned, it looks as if there were still quite a field for selling receivers to those who at present have none.

Besides this, many who are already owners will want to get the latest edition and so may be persuaded to buy. It looks to us as if there were some eighteen million people right now who are waiting for a good radio salesman to call at their front door with the kind of a set they want.

TALKING UP IN THE AIR

"Talking like a man up a tree" used to be a phrase which was not very complimentary. When you talk up in the air these days, however, you may be way ahead of the throng.

Camp Vail, New Jersey, has been the place where two-way talking between airplanes and the

cylinders and you recall that a spark system was the first style of wireless sending that was ever done. When the motors are hitting on every cylinder the aviator knows it. Every explosion tells its story to the listener's ears.

The invention which has done away with this trouble is a special kind of helmet and shielding for the wiring and receiving set. Not only is the roar of the propeller and the purr of the exhaust cut off from the aviator's ears, but besides this the electrical disturbances from the ignition system are short circuited out of the receiving set, so that it no longer sounds like two static storms fighting each other.

in the form of radio waves, while the short aerial which the plane is limited to can not use more than a small amount of energy.

THE HOLE IN THE WALL

When you build that new house you will find that the architect has specified a hole in the wall in almost every room.

What is this new idea? Merely a jack to take the plug of a loud speaker or pair of phones. In this way a single radio set located at a convenient point in the house will send music to any place where it is wanted.

Needs Piano Mover

It is not very easy to lug a 75-foot aerial around with you from room to room. Many of the portable sets are easily carried by a piano mover. Other people, however, find that the weight of the set plus the "A" and "B" batteries is enough so that they are apt to leave them in one place. Does this mean that the programs can be enjoyed only in the living room?

The modern way is to wire the house so as to change the location of the loud speaker to any place where it may be wanted. You will need to do only two things—first, connect the set to the wiring by inserting a special plug, and, second, plug the loud speaker wherever you want it into the wall receptacle.

No Lonely Nights

Many hotels are adopting this scheme, so that any guest may insert his own phones and get a good program. Usually a good station which is fairly close will be tuned in by the telephone operator and, of course, every listener will hear the same performance. Those who want some special program can rent an individual complete radio set, which is usually a non-radiating super-het, with its own loop aerial. In this way no one needs to be lonely in his hotel room at night.

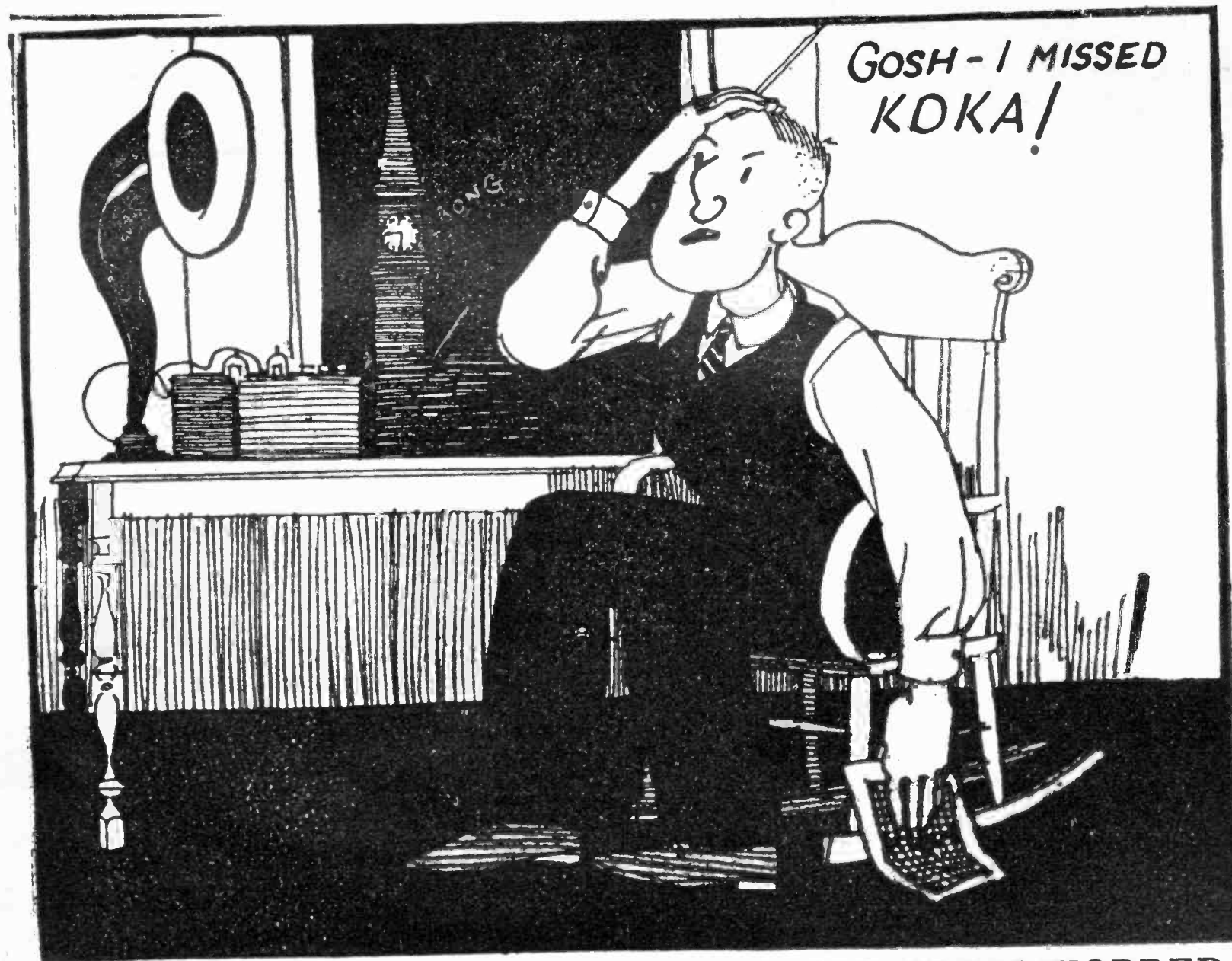

PITIFUL PLIGHT OF THE FAN WHO GOT CROSS-WORDED

ground has been brought to success. Way back in war time conversations were held between the aviators and their ground bases, but these were not very reliable and were largely done in telegraph code.

The Engine Broadcasts

One of the big troubles has been that the airplane carried an automatic broadcasting station of its own. Of course, the engine has a very powerful ignition system to fire the charge in its

Can Talk 30 Miles

As a result of this new device, the conversation from air to earth is just as clear as when you call up the office. The distance which can be covered with a two-way talk is about thirty miles. Even fifty miles further than this the flier can still pick up the land station, but his words will not carry back again. This is because the long aerial on the ground can send a great deal of power into the air

What's New at New York Show

Radio Has Many New Wonders to Surprise the Fans

An Interview from J. C. JOHNSON, Manager of Fourth National Exposition

WHAT is wrong with this picture?" That is the question you may be asking yourself when you look at your radio set—that is unless you have been to the radio show in New York.

The middle of September marks the time when it is considered perfectly good form to knock off a man's straw hat and jump on it in the middle of the street. It also marks the time when the big New York Radio Exposition proclaims the open season for DX hunting. From now on your friend will no longer seem bored when you start telling a radio tale but instead a glad look will glow in his eye and he will come back with a bigger story about picking up the coast than the one you told him.

Hear if You Can't See

What is new at the show? Of course, if you live close so that you can make it, you will naturally attend in person and there is no need for you to read any further. But if you live in another part of the country it will be entertaining to learn about the novelties which are on display for the first time.

If you are one of those who have been expecting to see some marvelous mechanism or invaluable invention which will revolutionize radio you are doomed to disappointment. But the exhibits show many ingenious refinements in radio reception and extraordinary progress in vacuum tube and loud speaker development, and the 250,000 radio fans who, it is expected, will flow through Grand Central Palace during the Fourth Annual National Radio Exposition, which opens Saturday, September 12th, in New York, will not be disappointed. The exhibits, which will pack three floors of the huge exposition building, will represent the flower of American inventive genius.

The Year's Biggest Efforts

The principle in development which has probably received the most attention

from engineers and inventors during the last twelve months is that of Audio Range. To explain what is meant look at Fig. 1. It is well known that sound is a vibration in the air. Unlike radio waves no tone or noise can pass across a vacuum.

Each octave that our ears hear means that the speed of vibrations is doubled. The lowest note that can be heard is 16 vibrations per second and many people have ears which cannot hear until a speed of 32 oscillations per second is reached. From there the notes go up to a high point of about 9,000 cycles. Some few musicians are able to hear a tone at 10,000 vibrations per second but

the same general shape of curve, but it falls off in loudness much sooner at both ends than a human ear does. If a piano is struck on three notes—the top, bottom, and middle keys—so that they all sound equally loud as we hear them in the same room then a broadcast reproduction heard on a set at a distance would show the upper and lower notes to be much fainter than the middle one.

It is this defect that the engineers have been working to overcome. Improvements are shown along several lines. Two places where great progress has been made are in audio transformers and in loud speakers. The detector tube has also come in for its share of at-

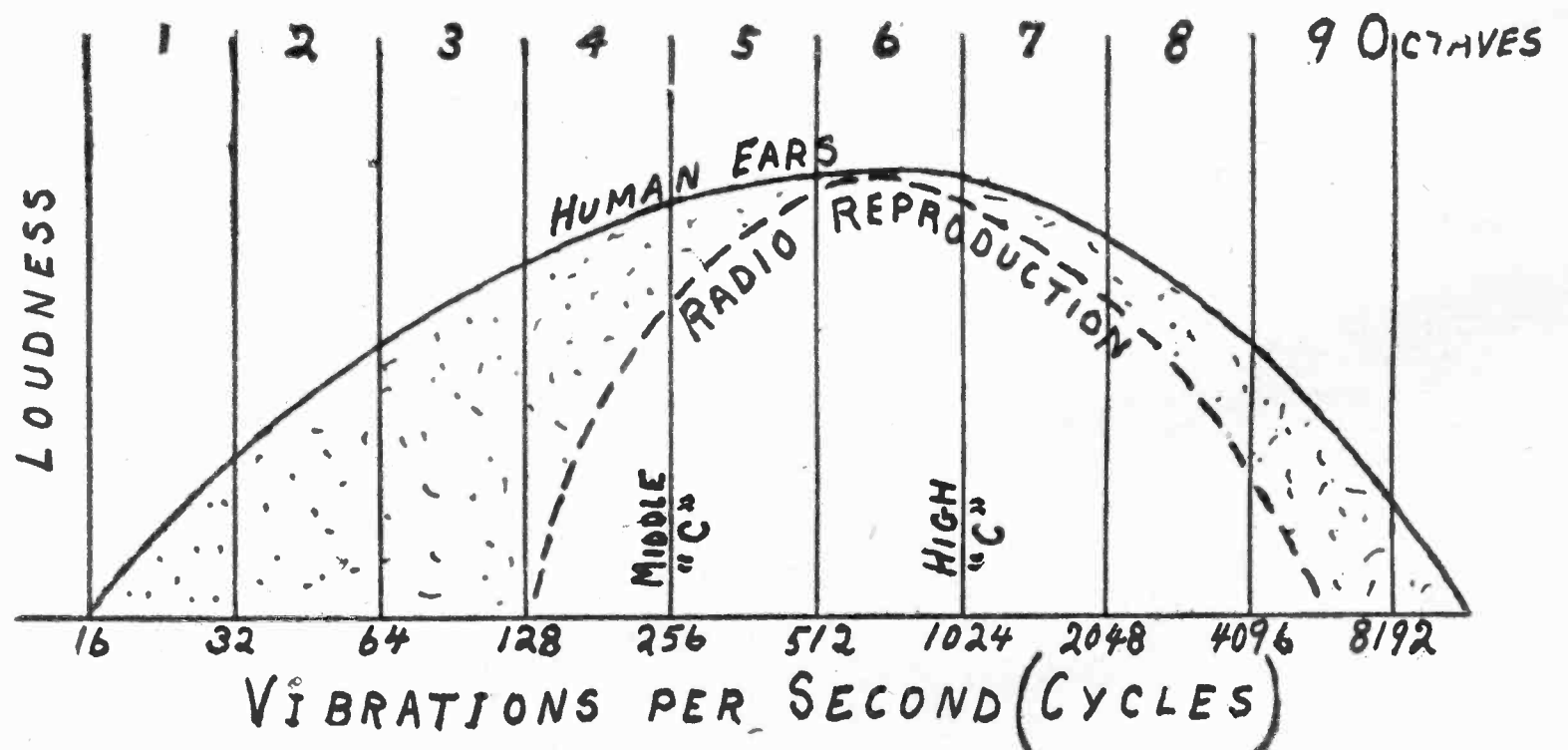

Fig. 1. Most of the Experiments This Last Year Have Tried to Cut Down the Shaded Area Above

most ears cannot hear such a high pitch as a tone.

Even musicians who are able to pick up the highest and lowest vibration speeds do not hear these tones very loudly, although they may be emitted by a tuning fork or piano with just as much power as a louder seeming note in the middle of the range. This is because our ears are most sensitive around 800 or 1,000 vibrations per second and fall off in their response to tones at the two ends of the range.

Deaf at the Ends

The music from an ordinary radio has

attention. Some improvement, too, has been made at the sending station end, so as to put stronger high and low audio frequency waves on the air.

The result of these developments is that leading radio manufacturers of the United States are bringing out loud speaker units in some cases almost as elaborate as the sets themselves. One of the new ones to be shown at the Exposition includes transformers, filters, chokes, rectifier tubes and amplifier tubes. When used in connection with a certain type of set, it may be employed also to energize the grid, plate and fla-

ment circuits of the receiver itself, thus constituting a complete AC operated set.

Carry Speaker with You

So striking have been the results attained in this work that for the first time the feat has been achieved of reproducing in the home an orchestra or a concert with the original volume, and yet without the least distortion. Because of the great volume thus obtainable, some of the loud speakers will be furnished with long cords, of as much as fifty feet, so that the loud speaker may be placed anywhere around your home.

A new super-power amplifier tube, designed for AC lighting mains, attracts a large amount of technical and popular attention at the Radio Exposition. Research has developed the fact that the employment of a powerful amplifying tube in the last audio stage will result in improvement in volume and in the quality of reproduction.

When Buzz Does Not Bother

The general idea of the alternating current tubes is of course not new. The principle is displayed in Fig 2. The grid and the plate are exactly like those of any ordinary tube. If the unit is to be used for wireless telegraphic code, then the filament may also be heated by AC of the same voltage as designed for its DC use. Of course, a loud hum will be heard, but this is no objection in code since the signal itself is in the nature of a buzz.

The reasons for the hum are two-fold. In the first place the "grid returns" as the lower terminal of the tuning coil is called must join the filament and the constantly changing voltage at this point by altering the grid bias makes a corresponding fluctuation in the plate current which is heard as noise. Besides this during the instant when the current though it is zero the filament cools down a trifle and this reduces the output of electrons. This periodic falling off in the electrons is also the cause of considerable noise.

Heated Until it Glows

The big feature of the alternating current bulb is that the filament is used as a heater for a tube which surrounds it. The filament proper has its two ends connected to the alternating current lines. The heat given off makes the tube F so hot that it glows and shoots

off electrons just like the wire filament of an ordinary tube.

This construction allows the grid return to be connected to the tube F which does not affect the grid bias as described above since it is not in any way connected to the AC line. Besides this it is so much larger and heavier than the fine filament wire that it does not cool down any to speak of during the instant of zero current and so gives off a steady stream of electrons.

AC Tube Now Practical

The new AC tubes on the market make use of this general principle but the details of construction have been so much improved that the bulb now becomes a practical proposition. If the life of the tubes turns out to be as great as those of the older models then they will undoubtedly become very popular. Other tubes designed in some cases for storage battery operation and

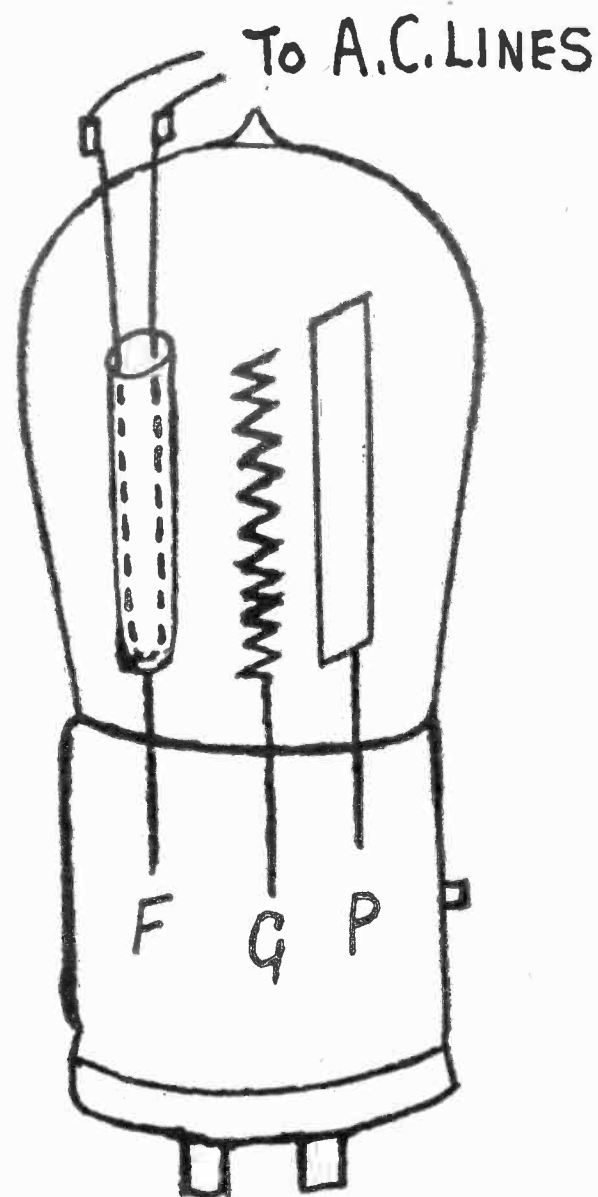

Fig. 2. Here is the Principle of the A. C. Vacuum Tubes

in others for dry cells will result in a remarkable improvement in reception this year.

Notwithstanding the progress made in meeting the problem of using the house alternating current to operate your radio, there is no immediate sign that either storage or dry batteries are likely to be displaced to a very large extent. Some of the larger radio manufacturers have been developing receivers

which will require no batteries whatever, and this year for the first time will place sets on the market that although operated on alternating current will be free from all hums which are characteristic of house current.

Will Not Kill Batteries

One set will include a glow lamp and a ballast lamp in its circuit which will automatically control filament and plate current and also the fluctuations of the AC lighting current. These sets are necessarily in the higher price ranges and are not likely therefore to take the place of the popular priced battery sets.

Many leading manufacturers this year will place on the market single control sets. In most of these cases the tuning condensers in the first three radio frequency stages are operated by one knob, thus enabling one station after another to be reproduced merely by moving the control throughout the scale. For extremely long-distance reception there is an added regeneration control whereby the additional sensitivity and selectivity provided by regeneration is brought into play.

New and improved styles of battery eliminators designed to provide plate voltages for any type of radio receiver will be brought out this year. There is practically no unit in radio receiving sets that will not be represented by new designs at the exposition. Grid leaks have been made air-tight, so that they are free from the influence of moisture; a new special steel has been utilized in making transformer cores, and a new design in battery construction will make them more efficient and of longer life.

Radio Set Like a Clock

The place that radio is expected to occupy in the home this year is reflected in the many beautiful cabinet designs that will be shown for the first time. A leading manufacturer of the neutrodyne group will show a five-tube set built in a cylindrical cabinet, not much larger nor less decorative than a mahogany clock. The front of this circular cabinet contains a cone speaker. Around the edge of the cone is a scale which indicates the tuning positions. The set is operated by a single tuning control.

In many other sets the cabinets will vie with the best that has been produced by the phonograph industry.

Fone Fun For Fans

Or Even Spaghetti

"Have you heard of my latest discovery?"

"No, what is it?"

"I've found how to tell the number of pieces of macaroni on a plate."

"How?"

"Why, you add up the ends and divide by two."—Crosley Radio.

And a Saxophone

"Are you fond of music?"

"Not very, but I prefer it to popular songs."—Boston Transcript.

On the Waiting List

"Well, sir," asked the musician, "what do you think of my compositions?"

"What do I think of them?" said the critic. "Well, they will be played when Gounod, Beethoven, and Wagner are forgotten."

"Really?"

"Yes, but not before."—London Mail.

A Home Collection

During a recent rainy Sunday a devout member of the Motor Club, who was attending church over his radio, inadvertently leaned forward and dropped a coin in his hat when the minister broadcast "Let Your Light So Shine."—The Road.

"So you have 'housemaids knee'," said the mistress. "Have you ever had it before?"

"No ma'am," replied the maid, "but it might be hereditary. My father used to hunt for four-leaf clovers, and my mother prayed a great deal."—Globe

Try It On the Dog

"Pardon me a moment," said the dentist to the victim, "but before beginning this work I must have my drill."

"Good gracious man!" exclaimed the patient, "can't you pull a tooth without a rehearsal?"—Globe.

In 15 Minutes I Will Give You the Secret of a Perfect Memory

I Guarantee to Increase Your Memory 100% In 10 Days

Not by any abstract, tiresome, difficult-to-master method; not by the old system of association of ideas or thoughts. Not by hard study,



GEO. J. SPINNER
Author and Educator

rotation exercises or repetition of words or sounds. It is not a book. There is nothing to study—nothing to repeat. It is by far the newest, best simplest method ever devised. I will give you a memory in one week's time that will surprise you. In one month things that occurred 30 days ago will be as fresh and clear in your mind as if they happened yesterday.

My Secret for 30 Years

I have given my secret to thousands. I have used it myself for more than 30 years. It enabled me to rise to my present position as an educator in professional and scientific circles; it gave me a good vocabulary, developed my powers of perception and analysis and fitted me to write on a hundred subjects.

Command Success

My VI-FLECT method of memory-building is for those who are ambitious to improve their business, professional, social or financial condition. VI-FLECT will develop your brain-power—your ability—lift you out of the rut; you will no longer stumble, mumble, nor grope for words with which to express yourself. You will be surprised how easily you can remember names, faces, dates, figures, appointments, duties, etc. It will enhance your importance as an employer, your value as a manager or employee, increase your worth, your ability, expertness, raise your salary, help you in business, professionally, socially, politically—in every way.

Learn My Secret

I prefer to place my secret within the easy reach of everyone. Therefore, the price I am going to ask for VI-FLECT—my wonderful method of memory-building, which I have developed and perfected during my 30 years of constant study and application is ONLY \$5.00.

Let nothing stand between you and a successful, happy, prosperous future. If it is not convenient to enclose the money, or if you prefer, I will mail your copy of VI-FLECT and you can hand the small amount to your postman when he delivers the package. The important thing is—SEND NOW.

COUPON

Geo. J. Spinner,
416 S. Dearborn St., MB738
Chicago, Ill.

Dear Sir: Please send me my copy of VI-FLECT for which I enclose \$5.00. I will try your VI-FLECT method of memory-building for 10 days, and if it does not increase my memory 100% I am to return it and you are to give me my money back without argument.

Name

Address

City State.....

Build Your Own A and B Battery Eliminator \$1

It is next to impossible to buy a battery eliminator that will operate rightly without alterations in your set. But for one dollar we will send you blue-print plans and instructions that will show you both how to construct a perfect eliminator and how to make the slight necessary changes in your receiver. Construction is extremely simple.

The device you will make with these plans ELIMINATES BOTH A AND B BATTERIES. Operates perfectly at all times from any standard house lighting current.

Send one dollar. Specify type of receiver and state whether direct or alternating current is used. Money back if not completely satisfied.

Do away with that costly, inconvenient battery nuisance!

Send for these plans to-day.

ENGINEERS' SERVICE COMPANY

SUITE 203

15 PARK ROW, NEW YORK, N. Y.

New Products of Unusual Interest

HOW TO ENGRAVE YOUR PANEL

Are you one of the fans who have built your own set? If you did you have no doubt been able to make it look as good as the factory built one in every way except one.

This is the matter of engraving the panel. Machines for doing this work have been very expensive up until now so that only the very large city stores were able to afford to own them and so only a small proportion of home-made sets have been properly engraved.

This difficulty has been overcome by

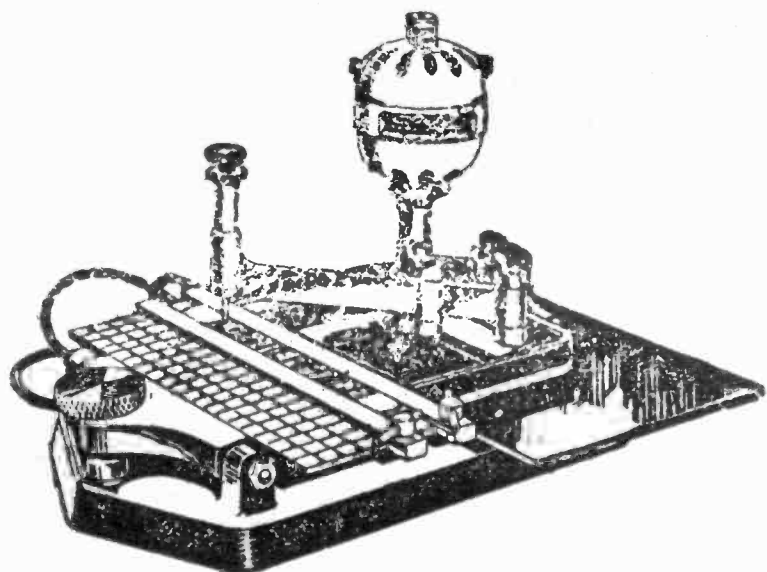

Fig. 1. This Machine Will Put Fancy Letters on Your Panel

the Rapid Engraving Machine, which is sold by the Branch Tool Sales Company of Chicago, for \$135.00. This is illustrated in Fig. 1. Such a price will enable many of the smaller dealers to put in a tool for lettering so that the surrounding fans will have the opportunity of getting their panels engraved like manufactured sets.

The machine will work on bakelite, hard rubber, Celeron, Formica, and all the regular kinds of panel material. It will take any length and thickness of stock up to 14 inches in width. The motor, supplied with the machine, works on 110 volts, either D. C. or A. C.

MAKING BUS BAR EYES

They say that a skillful seamstress does not try to stick the thread through the eye of the needle, but puts the needle around the thread. At any rate, there is no doubt that with bus bar you must

put an eye on the end if you want to make a good connection to screws and binding posts. How can you make a good eye?

Here is a pair of very handy and effective radio pliers, made by The William Schollhorn Company, New Haven, Conn. They are made of stamped steel,

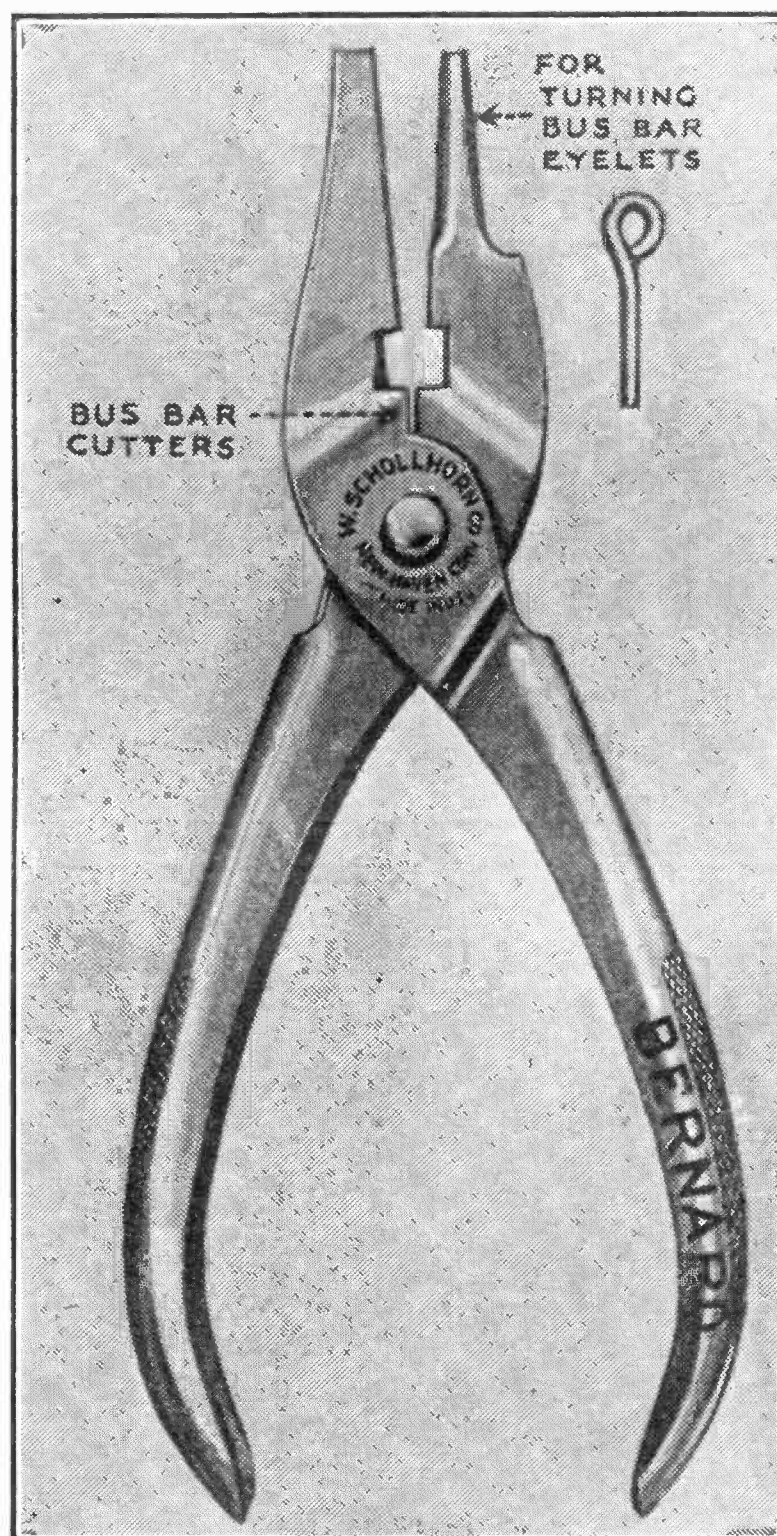

Fig. 2. Special Pliers That Will Make an Eye on the End of Bus Bar

very strong and sturdy, and are specially suitable for turning eyelets of various sizes in bus bar wire. Between the jaws (Fig. 2) just above the square recess is a flat vise-like surface to be used to flatten out the eyelet after it has been turned. Below the recess is a sharp pair of bus bar cutters. These pliers have the advantage of being large enough to afford a good grip without being excessively heavy.

Although these pliers are very effective, the price is quite low. Indeed they are on sale at some of the 5 and 10-cent stores for 10 cents.

A SINGING XYLOPHONE

The Eveready Orchestra broadcasting from WEAF, New York, and nine other tied-in stations, has been featuring a new instrument during their August and September concerts. This is called the vibraphone.

It is played by Joe Green, one of the best known Xylophone players in America. It has a very peculiar tone, something like a cross between a bell and a wail. The continuous tremelo is also suggestive of the human voice.

The vibraphone is one of the most unusual of musical instruments. At first glance it closely resembles an ordinary xylophone, except that its bars are made of steel instead of wood. However, on close examination it is found that at the top of each resonator tube (hung below the bars) is a little fan, driven by an electric motor. These fans set up a vibration or pulsation of air in the tube as the bar above it is struck; the rate of vibration is controlled by the speed of the fans, and can be adjusted by controlling the motor speed. Unlike the xylophone with its short staccato notes, the notes of the vibraphone can be drawn out indefinitely.

HEAR BEBE AND BEN

The series of short talks by the most prominent movie heroes and heroines, which were a regular feature of last winter's entertainments by Crandall's Saturday Nighters, is to be resumed this fall, according to Nelson Bell, impresario of the Saturday Nighters. The talks will be made from the studio of Station WJZ, New York, and will be sent to WRC by land wire. Among the screen stars who appeared on the Crandall programs of last winter were Milton Sills, Dorothy MacKaill, Bebe Daniels, Ben Lyon and Johnny Hines.

In addition to arranging for these movie talks, Mr. Bell is also making preparations for elaborate musical presentations by the foremost artists of the Capital. The Saturday Nighters will be on the air from WRC every Saturday night from 10:30 to midnight.

WE SAY—

**The
Brooklyn Radio Exposition**

WILL BRING—

**RECOGNITION
STABILIZED BUYING
NEW BUSINESS**

WHY DID—

Western Electric Corporation
David Grimes, Inc.
Marwol Radio Corporation
Tower Mfg. Company
Valley Electric Co.
C. J. Boissonnault Company, Inc.
Herzog Radio Corporation
Powerola Radio Corporation
Wildermuth & Co. (Atwater-Kent)
20th Century Radio Corp. (Garod)

G. J. Seedman & Co. (Grebe)
Victory Electric Supply Co. (Fada)
J. W. Weber, Jr., Inc. (Eagle)
McPhilben Radio Co. (De Forest)
Pyramid Motor Equipment Co. (Thermiodyne)
Marko Storage Battery
Willard Storage Battery Co.
and others

ELECT TO EXHIBIT AT THE BROOKLYN SHOW?

ASK THEM!

TIME: OCTOBER 17th to 24th, 1925

**PLACE: 23rd REGIMENT ARMORY, BEDFORD AND ATLANTIC AVES.,
BROOKLYN, N. Y.**

EXECUTIVE OFFICES

1-7 DeKalb Ave., Brooklyn, N. Y.

PHONE: TRIANGLE 4126

S. T. ROGERS, Managing Director

R DR RADIO PRESCRIBES.

NOTE: In this section the Technical Editor will answer questions of general interest on any radio matter. Any of our readers may ask not more than two questions, and if the subjects are of importance to most radio fans they will be answered free of charge in the magazine. If they are

of special interest to the questioner alone, or if a personal answer is desired, a charge of fifty cents will be made for each answer. This will entitle the questioner to a personal answer by letter. However, if the question requires considerable experimental work, higher rates will be charged.

Question. Why do various manufacturers advertise that their vernier dials have no gears? Are they supposed to be a disadvantage?

Answer. The most natural way of getting a reduced motion of the main shaft from the vernier knob is to connect the two by means of gears which have a ten to one or fifteen to one ratio. However, this scheme has one serious drawback, which is this: Ordinary gears cannot be cut so there is no play or lost motion between them. If you have a vernier dial on a standard condenser, the idea of using the special dial is to make the tuning smooth and easy.

If, however, owing to the back lash or lost motion, the vernier knob can be turned back and forth for some little distance without affecting the main shaft then the whole reason for using the vernier is practically all lost. If the movement is not smooth and even, you might as well omit the extra knob. To get around this difficulty some makers use a spring action, which always forces the gear teeth together. Some use friction disks without any teeth and others get around the difficulty by different methods of construction.

Question. I am using a four-tube regenoflex set. Would it improve the tone to connect a 1 mfd. condenser across the

terminals of the "B" battery?

Answer. In case you have a good "B" battery then a condenser across the terminals has absolutely no effect at all, as the high radio frequency waves find no difficulty in passing the battery. However, as the resistance rises, owing to old age or poor construction, a shunting condenser may have a slight amount of advantage. Such a condenser never does any harm to reception.

In all probability the reason you get poor quality with a reduced "B" battery voltage is that you do not cut down the "C" to correspond. With 67 volts of "B" do not use more than $1\frac{1}{2}$ volts of "C." We would also advise your trying two 45 volts "B" and disconnect the "C" entirely, joining the two wires together which run to this unit. If this gives distortion, then it would be well for you to get someone to look over your set, as the modern tubes work well as amplifiers on 45 volts plate, although without as much volume as with 90 volts.

Question. How and why is an audio transformer built with shielding?

Answer. If a single step of audio frequency amplification is used, there is not very much need for shielding it. However, if two or more steps are hooked up, then there may be considerable reaction between the different units. The current from the "B" battery flowing through the primary of the transformer to the plate of the vacuum tube makes a magnet out of the iron core and although this iron is bent around on itself to form a complete circuit still there is usually a small amount of leakage of magnetic lines of force.

If there is another transformer anywhere near these lines it will enter its iron and so affect the output from this unit. Such action oftentimes causes bad distortion. Usually it is not known by the listener since of course there are so many places where the tone may be dulled that it is hard to put your finger on any one. However, if this magnetic feed back action gets bad enough it is apt to cause a continuous howl to come from the set even when the aerial is disconnected.

Question. In a four-tube set would much saving result by using two sets of "B" batteries in par?

Answer. Dry cell batteries run down from two different causes. One of these is use and the other is old age. In case you take so much current from a dry cell (whether "A" or "B") that use is practically the controlling factor, then it pays to employ two in parallel, and so reduce the current drain to half on each unit.

On the other hand, if the amount of energy taken from the cells is small enough so that they eventually die, largely through old age, it evidently will cost nearly twice as much as to have two sets going at the same time since they both get old equally fast. From this you can draw some conclusion in regard to your own set. If you use eight tubes of the storage battery type you would certainly get more service per dollar spent than if you employed two "B's" or one of the heavy duty type. On the other hand, it would be absurd to do this with a one or two-tube set, used only a few hours per week.

Biltmore Master Reflex



We wish to announce our

Model V1 Master Reflex Receiver

which we are about to place on the market.

It has taken more than a year of constant improvement on one of the most popular reflex circuits which has ever been designed to develop this receiver.

And we have been well repaid for our efforts. We have completed this six tube machine, a set extreme in sensitiveness and excellent in selectivity.

But most important of all, the receiver is perfect in tone! We will compare it with any standard receiver, and guarantee that it wins the opinion of all who hear, that it has the finest tone of any receiver manufactured.

If your dealer is not yet supplied, we shall gladly fill your order direct, and if you are within a reasonable distance of Boston, we shall be pleased to have the receiver installed and demonstrated in your own home, and to your own satisfaction.

MODEL V1 \$115



DEALERS ARE REQUESTED TO WRITE

Please mention RADIO PROGRESS

THE BILTMORE RADIO COMPANY

BOSTON 30

MASS.

**UNITED STATES BROADCASTING STATIONS
ARRANGED ALPHABETICALLY BY
CALL LETTERS**

Abbreviations: W.L., wave length in meters; K.C., frequencies in kilocycles; W.P., wattpower of station.

K.C. W.L. W.P.

KDKA—Westinghouse Elec. & Mfg. Co., E. Pittsburg, Pa.	970-309-1000
KDPM—Westinghouse Elec. & Mfg. Co., Cleveland, O.	1200-250-500
KDZB—Frank E. Siefert, Bakersfield, Cal.	1430-210-500
KFAB—Nebraska Buick Auto Co., Lincoln, Neb.	880-341-500
KFAD—McArthur Bros. Mercantile Co., Phoenix, Ariz.	1100-273-100
KFAE—State College of Washington	860-349-500
KFAF—Western Radio Corp., Denver, Colo.	1080-278-500
KFAJ—University of Colorado, Boulder, Colo.	1150-261-100
KFAU—Boise High School, Boise, Idaho	1080-278-500
KFBK—Kimball Upson Co., Sacramento, Cal.	1210-248-100
KFCF—Frank A. Moore, Walla Walla, Wash.	1170-256-100
KFDM—Magnolia Petroleum Co., Beaumont, Tex.	950-316-500
KFDX—First Baptist Church, Shreveport, La.	1200-250-100
KFDY—S. Dak. Ste. Col. Ag. & Mech. Arts, Br'kngs., S. D.	1100-273-100
KFEQ—Scroggin, & Co. Bank, Oak, Nebr.	1120-268-500
KFFV—Graceland College, Lamoni, Iowa	1200-250-100
KFGC—Louisiana State Univ., Baton Rouge, La.	1120-268-100
KFGD—Oklahoma College for Women, Chickasha, Okla.	1190-252-200
KFGH—Leland Stanford Junior Univ., Stanford Univ., Cal.	1110-270-500
KFGX—First Presbyterian Church, Orange, Texas	1200-250-500
KFI—Earl C. Anthony, Los Angeles, Cal.	640-469-3000
KFIF—Benson Polytechnic Institute, Portland, Ore.	1210-248-100
KFIO—North Central High School, Spokane, Wash.	1130-266-100
KFIQ—First Methodist Church, Yakima, Wash.	1170-256-100
KFIZ—Daily Com'lth & Wis. R. S'les, Inc., Fondulac, Wis.	1100-273-100
KFJF—National Radio Mfg. Co., Oklahoma, Okla.	1150-261-225
KFJM—University of No. Dak., Grand Forks, No. Dak.	1080-278-100
KFKQ—Conway Radio Laboratories, Conway, Ark.	1200-250-100
KFKU—University of Kansas, Lawrence, Kas.	1090-275-100
KFKX—Westinghouse Elec. & Mfg. Co., Hastings, Neb.	1040-288-2000
KFLR—University of New Mexico, Albuquerque, N. Mex.	1180-254-200
KFLV—Swedish Evangelical Mission Church, Rockford, Ill.	1310-229-100
KFLZ—Atlantic Automobile Co., Atlantic, Iowa	1100-273-100
KFMQ—University of Arkansas, Fayetteville, Ark.	1000-300-500
KFMR—Morningside College, Sioux City, Iowa	1150-261-100
KFMX—Carleton College, Northfield, Minn.	890-337-750
KFNF—Henry Field Seed Co., Shenandoah, Iowa	1130-266-500
KFOA—Rhodes Dept. Store, Seattle, Wash.	660-454-500
KFON—Echophone Radio Shop, Long Beach, Cal.	1290-233-100
KFOO—Latter Day Saints Univ., Salt Lake City, Utah	1270-236-250
KFOR—David City Tire & Electric Co., David City, Neb.	1330-226-100
KFOX—Technical High School, Omaha, Nebr.	1210-248-100
KFPG—Oliver S. Garretson, Los Angeles, Cal.	1260-238-100
KFPR—Los Angeles County Forestry, Los Angeles, Cal.	1300-231-500
KFPY—Symons Investment Co., Spokane, Wash.	1130-266-100
KFQA—The Principa, St. Louis, Mo.	1150-261-100
KFQB—Searchlight Publishing Co., Fort Worth, Texas	1140-263-150
KFQC—Kidd Brothers Radio Shop, Taft, Cal.	1300-231-100
KFQZ—W. E. Riker, Holy City, Calif.	1350-222-100
KFQZ—Taft Products Co., Hollywood, Calif.	1330-226-250
KFRB—Hall Bros., Beeville, Texas	1210-248-250
KFRU—Etherical Radio Co., Bristow, Okla.	760-395-500
KFSG—Echo Park Evangelistic Asso., Los Angeles, Cal.	1090-275-500
KFUM—W. D. Pyle, Colorado Springs, Colo.	1240-242-100
KFUO—Concordia Seminary, St. Louis, Mo.	550-545-500
KFUT—University of Utah, Salt Lake City, Utah	1150-261-100
KFVE—Film Corporation of America, St. Louis, Mo.	1250-240-500
*KFV—Clarence B. Juneau, Hollywood, Cal.	1440-208-250
KFVW—Airfan Radio Corporation, San Diego, Cal.	1220-246-500
KFWA—Browning Bros. Co., Ogden, Utah	1150-261-500
KFWB—Warner Bros. Pictures, Inc., Hollywood, Cal.	1190-252-500
KFWD—Arkansas Light & Power Co., Arkadelphia, Ark.	1130-266-500
KFWH—F. Wellington Morse, Jr., Chico, Cal.	1180-254-100
KFWI—Radio Entertainments, Inc., So. San Fran., Cal.	1360-220-500
KFWM—Oakland Educational Society, Oakland, Cal.	1430-207-500
KFWO—Lawrence Mott, Avalon, California	1420-211-250
*KFWM—Oakland Education Society, Oakland, Cal.	1430-207-500
KFWU—Louisiana College, Pineville, La.	1260-238-100
KGO—General Electric Co., Oakland, Cal.	830-361-3000
KGU—Marion A. Mulrony, Honolulu, Hawaii	1110-270-500
KGW—Portland Morning Oregonian, Portland, Ore.	610-491-500
KHJ—Times-Mirror Co., Los Angeles, Cal.	740-405-500
*KHQ—Louis Wasmer, Seattle, Wash.	1100-273-100
KLS—Warner Bros. Radio Supplies Co., Oakland, Cal.	1240-242-250
KLX—Tribune Publishing Co., Oakland, Cal.	590-509-500
KLZ—Reynolds Radio Co., Denver, Colo.	1130-266-250
*KMA—May Seed & Nursery Co., Shenandoah, Iowa	1190-252-500
KMO—Love Electric Co., Tacoma, Wash.	1200-250-100
KNX—Los Angeles Express, Los Angeles, Cal.	890-337-500
KOA—General Electric Co., Denver, Colo.	930-322-2000
KOB—New Mexico Col. of Agriculture, State Col., N. Mex.	860-349-750
KOIL—Monarch Manufacturing Co., Council Bluffs, Ia.	1080-278-500
KOP—Detroit Police Dept., Detroit, Mich.	1080-278-500
KPO—Hale Bros., San Francisco, Cal.	700-428-500
KPRC—Houston Printing Co., Houston, Texas	1010-297-500
*KPSN—Pasadena Star-News, Pasadena, Cal.	950-316-1000
KQP—Apple City Radio Club, Hood River, Ore.	1110-270-100
KQV—Double-Hill Electric Co., Pittsburg, Pa.	1090-275-500

K.C. W.L. W.P.

KSAC—Kansas State Agric. College	880-341-500
KSD—Post-Dispatch, St. Louis, Mo.	550-545-750
KSL—The Radio Service Corp., Salt Lake City, Utah	1000-300-1000
KTAB—Tenth Ave. Baptist Church, Oakland, Cal.	1390-216-500
*KTBI—Bible Institute of Los Angeles, Los Angeles, Cal.	1020-294-750
KTCL—American Radio Tel. Co., Inc., Seattle, Wash.	980-310-1000
KTHS—New Arlington Hotel Co., Hot Springs, Ark.	800-375-500
KTW—First Presbyterian Church, Seattle, Wash.	660-454-1000
KUO—Examiner Printing Co., San Francisco, Cal.	1220-246-150
KUOM—State Univ. of Montana, Missoula, Mont.	1230-244-250
KWKC—Wilson Duncan Studios, Kansas City, Mo.	1270-236-100
KWWG—City of Brownsville, Brownsville, Texas	1080-278-500
KWKH—W. G. Paterson, Shreveport, La.	1110-273-250
KYW—Westinghouse Elec. & Mfg. Co., Chicago, Ill.	560-535-1500
KZKZ—Electrical Supply Co., Manila, P. I.	1110-270-100
KZM—Preston D. Allen, Oakland, Cal.	1240-242-100
KZRO—Far Eastern Radio, Manila, P. I.	1350-222-500
WAAB—Valdemar Jensen, New Orleans, La.	1120-268-100
WAAC—Tulane University, New Orleans, La.	1090-275-100
WAAF—Chicago Daily Drovers Journal, Chicago, Ill.	1080-278-200
WAAM—I. R. Nelson Co., Newark, N. J.	1140-263-500
WAAW—Omaha Grain Exchange, Omaha, Neb.	1080-278-500
WABA—Lake Forest University, Lake Forest, Ill.	1320-227-200
WABI—Bangor Hydro-Electric Co., Bangor, Me.	1250-240-100
WABO—Lake Avenue Baptist Church, Rochester, N. Y.	1080-278-100
WABX—Henry B. Joy, Mount Clemens, Mich.	1220-246-150
WADC—Allen Theatre, Akron, O.	1160-258-100
WAFD—Albert B. Parfet Co., Port Huron, Mich.	1170-256-500
WAHG—A. H. Grebe Co., Richmond Hill, N. Y.	950-316-500
WAMD—Hubbard & Co., Minneapolis, Minn.	1230-244-500
WARC—Am. Rad. & Research Corp., Medf'd H'side, Mass.	1150-261-100
WBAA—Purdue University, West Lafayette, Ind.	1100-273-250
WBAA—Pennsylvania State Police, Harrisburg, Pa.	1090-275-500
WBAO—James Millikin University, Decatur, Ill.	1110-270-100
WBAP—Wortham-Carter Publishing Co., Fort Worth, Tex.	630-476-1000
WBAX—John H. Stenger, Jr., Wilkes-Barre, Pa.	1170-256-100
WBAY—Erner & Hopkins Co., Columbus, Ohio	1020-293-500
WBBG—Irving Vermilya, Mattapoisett, Mass.	1210-248-100
WBBL—Grace Covenant Church, Richmond, Va.	1310-220-100
WBBM—Atlas Investment Co., Chicago, Ill.	1330-226-1500
WBBP—Petoskey High School, Petoskey, Mich.	1260-238-200
WBBR—People's Pulpit Assoc., Rossville, N. Y.	1100-273-500
WBES—Bliss Electrical School, Takoma Park, Md.	1350-222-100
WBOQ—A. H. Grebe Co., Richmond Hill, N. Y.	1270-236-100
WBT—Southern Radio Corp., Charlotte, N. C.	1090-275-250
WBZ—Westinghouse Elec. & Mfg. Co., Springfield, Mass.	900-331-2000
WCAC—Connecticut Agric. College, Mansfield, Conn.	1090-275-500
WCAD—St. Lawrence University, Canton, N. Y.	1140-263-250
WCAE—Kaufmann & Baer Co., Pittsburg, Pa.	650-461-500
WCAH—Entrekin Electric Co., Columbus, O.	1130-266-500
WCAJ—Nebraska Wesleyan University, Univ. Place, Nebr.	1180-275-100
WCAL—St. Olaf College, Northfield, Minn.	890-337-500
WCAO—A. A. & A. S. Brager, Baltimore, Md.	1090-275-100
WCAP—Chesapeake & Potomac Tel. Co., Wash., D. C.	640-469-500
WCAR—Southern Radio Corp. of Texas, San Antonio, Tex.	1140-263-100
WCAU—Durham & Co., Philadelphia, Pa.	1080-278-500
WCAX—University of Vermont, Burlington, Vt.	1200-250-100
WCBC—University of Michigan, Ann Arbor, Mich.	1310-229-200
WCBG—Wilbur G. Voliva, Zion, Ill.	870-345-2000
WCBN—Foster & McDonnell, Chicago, Ill.	1130-266-500
WCBQ—First Baptist Church, Nashville, Tenn.	1270-236-100
WCCO—Washburn Crosby Co., Minneapolis, Minn.	720-416-5000
WCEE—Charles E. Erbstein, Elgin, Ill.	1090-275-1000
WCLS—H. M. Couch, Joliet, Ill.	1400-214-100
WCM—Texas Markets & Warehouse Dept., Austin, Tex.	1120-268-250
WCN—Foster & McDonnell, Chicago, Ill.	1130-266-500
WCSH—Congress Square Hotel Co., Portland, Me.	1170-256-500
WCTS—C. T. Sherer Co., Worcester, Mass.	1120-268-500
WCUW—Clark University, Worcester, Mass.	1260-238-250
*WCX and WJR—The Detroit Free Press and J. W. Jett Radio and Phonograph Co., Pontiac, Mich., (operating jointly)	580-517-1500
WDAE—Tampa Daily News, Tampa, Fla.	1100-273-250
WDAG—J. Laurence Martin, Amarillo, Tex.	1140-263-100
WDBE—Gilham-Schoen Electric Co., Atlanta, Ga.	1080-278-100
WDBK—M. F. Broz Radio Store, Cleveland, O.	1320-227-100
WDBO—Rollins College, Winter Park, Fla.	1250-240-100
WDBR—Tremont Temple Baptist Church, Boston, Mass.	1150-261-100
WDBY—North Shore Congregational Church, Chicago, Ill.	1160-258-500
WDWF—Dutee W. Flint, Cranston, R. I.	680-441-500
WDZ—James L. Bush, Tuscola, Ill.	1080-278-100
*WEAF—American Tel. & Tel. Co., New York, N. Y.	610-492-5000
WEAH—Hotel Lassen (Rigby-Gray H. Co.), Wichita, Kas	1120-268-100
WEAI—Cornell University, Ithaca, N. Y.	1180-254-500
WEAJ—University of So. Dakota, Vermilion, So. Dak.	1080-278-100
WEAM—Borough of North Plainfield, No. Plainfield, N. J.	1150-261-250
WEAN—Shepard Co., Providence, R. I.	1110-270-250
WEAO—Ohio State University, Columbia, Ohio	1020-294-500
WEAR—Goodyear Tire & Rubber Co., Cleveland, Ohio	770-389-1000
WEAU—Davidson Bros. Co., Sioux City, Iowa	1090-275-100
WEAL—Iris Theater, Houston, Tex.	1110-270-500
WEBC—Walter C. Bridges, Superior, Wis.	1240-242-100
WEBH—Edgewater Beach Hotel Co., Chicago, Ill.	810-370-1000
WEBJ—Third Avenue Railway Co., New York, N. Y.	1100-273-500

The Heart of Your Radio Set

A Grid Leak is essential on every set. There are few sets made which wouldn't be improved by the use of a Variable Grid Leak.

Even the set makers admit that.

But those makers say—"Show us a **good** Variable Grid Leak,"—because they know that most of the variables on the market have been a failure.

Right now -- we're showing them

Buy It

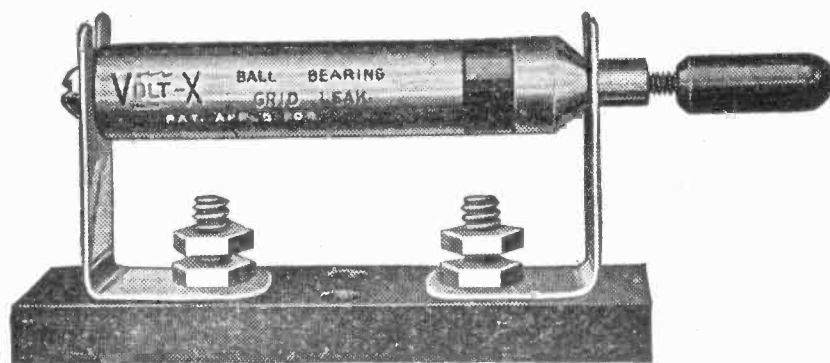

Try It

Volt-X Ball-Bearing
Variable Grid Leak

If you are not satisfied, return it and get your money back

This GRID LEAK is made by an organization which has been handling delicate electrical instruments for years. We know what it means to build accurately and substantially. We KNOW that this GRID LEAK is as nearly perfect as human hands and precise machinery can make it —we're glad to have you try it with the knowledge that if it doesn't do what we claim for it, your money will be refunded.

Clip the coupon, and send it in with \$1.00—a grid leak will be mailed at once.

BURTON & ROGERS MFG. CO.

755 Boylston St.

Boston, Mass.

Please
send me one
of your VOLT-X
VARIABLE GRID
LEAKS.

I enclose \$1.00 with
the understanding that
this merchandise is guaran-
teed to give satisfaction, or
may be returned.

NAME.

ADDRESS.

K.C. W.L. W.P.

WEBL—Radio Corp. of America, United States (portable)	1330-226-100
WEBM—Radio Corp. of America, United States (portable)	1330-226-100
WEBW—Beloit College, Beloit, Wis.	1120-268-500
WEEI—Edison Electric Illuminating Co., Boston, Mass.	630-476-500
WEMC—Emmanuel Missionary Col., Berrien Springs, Mich.	1050-286-500
WENR—All-American Radio Corporation, Chicago, Ill.	1130-266-100
WEW—St. Louis University, St. Louis, Mo.	1210-248-100
WFAA—Dallas News & Dallas Journal, Dallas, Tex.	630-476-500
WFAV—University of Nebraska, Lincoln, Neb.	1090-275-500
WFBG—William F. Gable Co., Altoona, Pa.	1080-278-100
WFBH—Concourse Radio Corp., New York, N. Y.	1100-273-500
WFBI—Galvin Radio Supply Co., Camden, N. J.	1270-236-250
WFBL—Onondoga Hotel, Syracuse, N. Y.	1190-252-100
WFBM—Merchant Heat & Light Co., Indianapolis, Ind.	1120-268-250
WFBR—Fifth Infantry, Maryland N. G., Baltimore, Md.	1180-254-100
WFDF—Frank D. Fallain, Flint, Mich.	1280-234-100
WFI—Strawbridge & Clothier, Philadelphia, Pa.	760-395-500
WFKB—Francis K. Bridgman, Chicago, Ill.	1380-217-100
WGAQ—W. G. Paterson, Shreveport, La.	1110-273-250
WGAZ—South Bend Tribune, South Bend, Ind.	1090-275-250
WGBA—Jones Electric & Radio Mfg. Co., Baltimore, Md.	1180-254-100
WGBB—Harry H. Carman, Freeport, N. Y.	1240-244-100
WGBF—Finke Furniture Co., Evansville, Ill.	1270-236-100
WGBQ—Stout Institute, Menomonee, Wis.	1280-234-100
WGBS—Gimbel Bros., New York	950-316-500
*WGBU—Florida Cities Fin. Co., Fulford By-The-Sea, Fla.	1080-278-500
WGBX—University of Maine, Orono, Me.	1190-252-100
WGCP—D. W. May, Newark, N. J.	1190-252-500
WGES—Coyne Electrical School, Oak Park, Ill.	1200-250-500
WGHP—Geo. H. Phelps, Detroit, Mich.	1110-270-500
WGMU—A. H. Grebe & Co., Inc. (portable), Richmond Hill, N. Y.	1270-236-100
WGPB—George Harrison Phelps, Inc., Detroit, Mich.	1110-270-500
WGN—The Tribune, Chicago, Ill.	810-370-1000
WGR—Federal Telephone Mfg. Corp., Buffalo, N. Y.	940-319-750
WGS—Georgia School of Technology, Atlanta, Ga.	1110 270-500
WGY—General Electric Co., Schenectady, N. Y.	790-380-2000
WHA—University of Wisconsin, Madison, Wis.	560-535-750
WHAD—Marquette Univ. and Mil. Jour., Mil., Wis.	1000-275-500
WHAG—University of Cincinnati, Cincinnati, O.	1290-233-100
WHAM—University of Rochester, Rochester, N. Y.	1080-278-100
WHAP—William H. Taylor Finance Corp., Brooklyn, N. Y.	1250-250-100
WHAR—Seaside Hotel, Atlantic City, N. J.	1090-275-500
WHAS—Courier Journal & Louisville Times	750-400-500
WHAT—George W. Young, Minneapolis, Minn.	1140-263-500
WHAV—Wilmington Electric Spectly Co., Wilmington, Del.	1130-266-100
WHAZ—Rensselaer Polytechnic Institute, Troy, N. Y.	790-380-500
WHB—Sweeney School Co., Kansas City, Mo.	820-366-500
WHBF—Beardsley Specialty Co., Rock Island, Ill.	1350-222-100
WHBH—Culver Military Academy, Culver, Ind.	1350-222-100
WHBP—Johnstown Automobile Co., Johnstown, Pa.	1170-256-100
WHBW—D. R. Kienzle, Philadelphia, Pa.	1390-216-100
WHDI—Wm. Hood Dunwoody I. Inst., Minneapolis, Minn.	1080-278-500
WHEC—Hickson Electric Co., Inc., Rochester, N. Y.	1160-258-100
WHK—Radiovox Co., Cleveland, O.	1100-273-250
WHN—George Schubel, New York, N. Y.	830-361-500
WHO—Bankers Life Co., Des Moines, Iowa	570-526-500
WHT—Radiophone Broadcasting Corporation, Deerfield, Ill.	1260-238-1500
WIAD—Howard R. Miller, Philadelphia, Pa.	1200-250-100
WIAS—Home Electric Co., Burlington, Iowa	1180-254-100
WIBA—The Capital Times Studio, Madison, Wisc.	1270-236-100
WIBC—L. M. Tate Post No. 39, V.F.W. St. Petersburg, Fla.	1350-222-100
WIBK—University of the City of Toledo, Toledo, O.	1460-205-100
*WIBO—Nelson Brothers, Chicago, Ill.	1330-226-1000
WIBT—O. E. Miller, New York, N. Y.	1420-211-100
WIBW—L. L. Dill, Logansport, Ind.	1360-220-100
WIL—St. Louis Star, Benson Radio Co., St. Louis, Mo.	1100-273-250
WIP—Gimbel Bros., Philadelphia, Pa.	590-508-500
WJAD—Jackson's Radio Eng. Laboratories, Waco, Texas	850-353-500
WJAG—Norfolk Daily News, Norfolk, Nebr.	1110-270-250
WJAK—Clifford L. White, Greentown, Ind.	1180-254-100
WJAM—D. M. Perham, Cedar Rapids, Ia.	1120-268-100
WJAR—The Outlet Co., Providence, R. I.	980-306-500
WJAS—Pittsburgh Radio Supply House, Pittsburgh, Pa.	1090-275-500
WJAZ—Zenith Radio Corp., Chicago, Ill. (portable)	1120-268-100
WJBC—Hummer Furniture Co., La Salle, Ill.	1280-234-100
WJBD—Ashland Broadcasting Committee, Ashland, Wisc.	1290-233-100
*WJBI—Robert S. Johnson, Red Bank, N. J.	1370-219-250
WJJ—Supreme Lodge L. O. Moose, Mooseheart, Ill.	990-303-500
*WJR and WCX—Jewett Radio and Phonograph Co., and The Detroit Free Press, Pontiac, Mich., (operat- ing jointly)	580-517-1500
WJY—Radio Corporation of America, New York, N. Y.	740-405-1000
WJZ—Radio Corporation of America, New York, N. J.	660-454-1000
*WKAA—H. F. Paar, Cedar Rapids, Iowa	1080-278-500
WKAF—WKAF Broadcasting Co., Milwaukee, Wis.	1150-261-250
WKAQ—Radio Corporation of Porto Rico, San Juan, P. R.	880-341-500
WKAR—Michigan Agric. Col., E. Lansing, Mich.	1050-286-1000
*WKBE—K. and B. Electric Co., Webster, Mass.	1300-231-100
WKBG—C. L. Carrell (portable), Chicago, Ill.	1390-216-100
WKRC—Kodel Radio Corp., Cincinnati, O.	710-422-1000
WKY—E. C. Hull and H. S. Richards, Oklahoma, Okla.	1090-275-100
WLAL—First Christian Church, Tulsa, Okla.	1200-250-150
WLB—University of Minnesota, Minneapolis, Minn.	1080-278-500
WLBL—Wisconsin Dept. of Markets, Stevens Point, Wis.	1080-278-500
WLIT—Lit Bros., Philadelphia, Pa.	760-395-500

*Additions and corrections.

K.C. W.L. W.P.

WLS—Sears, Roebuck Co., Chicago, Ill.	870-345-500
WLTS—Lane Technical High School, Chicago, Ill.	1160-258-100
WLW—Crosley Radio Corp., Harrison, O.	710-422-5000
WLWL—Mis. Soc. of St. Paul the Apostle, New York	1040-288-1000
WMAC—Clive B. Meredith, Cazenovia, N. Y.	1090-275-100
WMAF—Round Hills Radio Corp., Dartmouth, Mass.	680-441-1000
WMAF—Round Hills Radio Corp., Dartmouth, Mass.	833-360-100
WMAK—Norton Laboratories, Lockport, N. Y.	1130-466-500
WMAQ—Chicago Daily News, Chicago, Ill.	670-448-500
WMAY—Kingshighway Presbyterian Church, St. Louis, Mo.	1210-248-100
WMAZ—Mercer University, Macon, Ga.	1150-261-500
WMBB—American Bond & Mortgage Co., Chicago, Ill.	1200-250-500
WMBF—Fleetwood Hotel, Miami Beach, Fla.	780-384-500
WMC—Commercial Appeal, Memphis, Tenn.	600-500-500
WMCA—Greeley Square Hotel Co., New York, N. Y.	880-341-500
WNAB—Shepard Stores, Boston, Mass.	1200-250-100
WNAC—Shepard Stores, Boston, Mass.	1070-280-500
WNAD—University of Oklahoma, Norman, Okla.	1180-254-250
WNAP—Wittenberg College, Springfield, Ohio	1210-248-100
WNAT—Lennig Bros. Co., Philadelphia, Pa.	1200-250-100
WNAV—People's Tel. & Tel. Co., Knoxville, Tenn.	1290-233-500
WNAX—Dakota Radio Apparatus Co., Yankton, S. Dak.	1230-244-100
*WNOX—People's Tel. & Tel. Co., Knoxville, Tenn.	1120-268-500
WNJ—Radio Shop of Newark, Newark, N. J.	1290-233-100
WNYC—City of New York, New York, N. Y.	570-526-1000
WOAI—Southern Equipment Co., San Antonio, Texas	760-395-1500
WOAN—James D. Vaughn, Lawrenceburg, Tenn.	1060-283-500
WOAW—Woodmen of the World, Omaha, Nebr.	570-526-1000
WOC—Palmer School of Chiropractic, Davenport, Iowa	620-484-5000
*WOI—Iowa State College, Ames, Iowa	1110-270-750
*WOK—Neutrowound Radio Mfg. Co., Homewood, Ill.	1380-217-500
WOO—John Wanamaker, Philadelphia, Pa.	590-508-500
WOQ—Unity School of Christianity, Kansas City, Mo.	1080-278-500
WOR—L. Bamberger & Co., Newark, N. J.	740-405-500
WORD—People's Pulpit Association, Batavia, Ill.	1090-275-2000
WOS—Missouri State Marketing Bureau, Jefferson City, Mo.	680-441-500
WOWL—Owl Battery Co., New Orleans, La.	1110-270-100
WOWO—Main Auto Supply Co., Fort Wayne, Ind.	1320-227-500
WPAJ—Doolittle Radio Corporation, New Haven, Conn.	1120-268-100
WPG—Municipality of Atlantic City, Atlantic City, N. J.	1000-300-500
WPSC—Pennsylvania State College, State College, Pa.	1150-261-500
WQAA—Horace A. Beale, Jr., Parkesburg, Pa.	1360-220-500
WQAC—Gish Radio Service, Amarillo, Tex.	1280-234-100
WQAM—Electrical Equipment Co., Miami, Fla.	1120-268-100
WQAN—Scranton Times, Scranton, Pa.	1200-250-100
WQAO—Calvary Baptist Church, New York, N. Y.	833-360-100
WQJ—Calumet Rainbow Broadcasting Co., Chicago, Ill.	670-448-500
WRAF—The Radio Club, Laporte, Ind.	1340-224-100
WRAC—Economy Light Co., Escanaba, Mich.	1170-256-100
WRAM—Lombard College, Galesburg, Ill.	1230-244-100
WRAP—Antioch College, Yellow Springs, Ohio	1140-263-100
WRAX—Flexon's Garage, Gloucester City, N. J.	1120-268-250
WRBC—Immanuel Lutheran Church, Valparaiso, Ind.	1080-278-500
WRC—Radio Corporation of America, Washington, D. C.	640-469-1000
WREO—Reo Motor Car Co., Lansing, Mich.	1050-286-500
WRK—Doron Bros. Electrical Co., Hamilton, O.	1110-270-200
WRM—University of Illinois, Urbana, Ill.	1100-273-500
WRMU—A. H. Grebe & Co., Richmond Hill, N. Y.	1270-236-100
WRNY—Experimenter Publishing Co., New York, N. Y.	1160-258-500
WRR—Dallas Police & Fire Dept., Dallas, Tex.	1150-261-350
WRW—Tarrytown Radio Research Labs., Tarrytown, N. Y.	1100-273-500
WSAC—Clemson Agric. Col., Clemson College, S. C.	890-337-500
WSAI—United States Playing Card Co., Mason, O.	920-326-500
WSAJ—Grove City College, Grove City, Pa.	1310-229-250
WSAN—Allentown Call Publishing Co., Allentown, Pa.	1310-229-100
WSAR—Doughty & Welch Electric Co., Fall River, Mass.	1180-254-100
WSAV—Clifford W. Vick Radio Const. Co., Houston, Tex.	1210-248-100
WSB—Atlanta Journal, Atlanta, Ga.	700-428-500
WSBC—World Battery Co., Chicago, Ill.	1430-210-200
WSBF—Stix, Baer & Fuller, St. Louis, Mo.	1100-273-250
WSDA—The City Temple, New York, N. Y.	1140-263-250
WSKC—World's Star Knitting Co., Bay City Mich.	1150-261-100
WSMB—Saenger A'm'h Co., & Maison Blanche N. O. La.	940-319-500
WSMK—S. M. K. Radio Corp., Dayton, Ohio	1090-275-500
WSOE—School of Eng'rng of Milwaukee, Milwaukee, Wis.	1220-246-500
WSRO—Radio Co., Hamilton, Ohio	620-483-100
WSUI—State University of Iowa, Iowa City, Iowa	620-484-500
WSY—Alabama Polytechnic Institute, Auburn, Ala.	1200-250-500
WTAB—Fall River Daily Herald Pub. Co., Fall R'vr, Mass.	1130-266-100
WTAC—Penn. Traffic Co., Johnstown, Pa.	1430-210-100
WTAM—Willard Storage Battery Co., Cleveland O.	770-389-2500
WTAQ—S. H. Van Gorden & Son, Osseo, Wis.	1180-254-100
WTAR—Reliance Electric Co., Norfolk, Va.	1150-261-100
WTAS—Charles E. Erbstein, Elgin Ill.	990-302-1500
WTAT—Edison Illum'ing Co., Boston, Mass. (portable)	1230-302-100
WTAW—Agric. & Mech. Col. of Texas, Col. Station, Tex.	1110-270-250
WTHS—Flint Senior High School, Flint, Mich.	1370-219-250
WTIC—Travelers Insurance Co., Hartford, Conn.	860-349-500
WWAD—Wright & Wright, Philadelphia, Pa.	1200-250-100
WWAE—Lawrence J. Crowley, Plainfield, Ill.	1240-242-500
WWAO—Michigan College of Mines, Houghton, Mich.	1140-263-250
*WWGL—Radio Engineering Corp., Richmond Hill, N. Y.	1410-213-500
WWI—Ford Motor Co., Dearborn, Mich.	1130-266-500
WWJ—Detroit News, Detroit, Mich.	850-353-1000
WWL—Loyala University, New Orleans, La.	1090-275-100



STATIC ELIMINATION

WITH the approach of summer, every radio fan looks with a certain amount of dread to the Enigma of Radio—Static. For more than a quarter of a century, scientists in many parts of the world have applied their knowledge and skill to the problem of eliminating Static. Most of their attempts have resulted in failure.

Science recognizes but one device capable of curbing the annoying electrical disturbances, and that is the loop antenna. Electrical storms, like other weather disturbances, find their origin in various points of the compass. It is obvious, then, that by the use of a directional loop turned to a direction away from the disturbance, the disagreeable static noises may be tuned out.

The superior construction of the DTW IMPORTED COLLAPSIBLE LOOP enables it to perform this function to much better advantage than other loop antenna devices. Forty-two inches high by forty inches wide, its inductance consists of fourteen turns of genuine Litzendraht cable, made up of sixty individual strands, insulated, twisted and covered with double green silk.

The woodwork is mahogany and all metal parts are highly nicked. A graduated metal table at the base accurately gives the station direction. The turns are sectionized and by unique design all "dead end" effect is absolutely eliminated. The center tap permits its use without modification for all types of Super Heterodynes. The loop is collapsible and by means of the adjustable slide it may be actually used as the tuning unit of the set. No other loop incorporates such perfection of design, and no other loop can give such marvelous results.

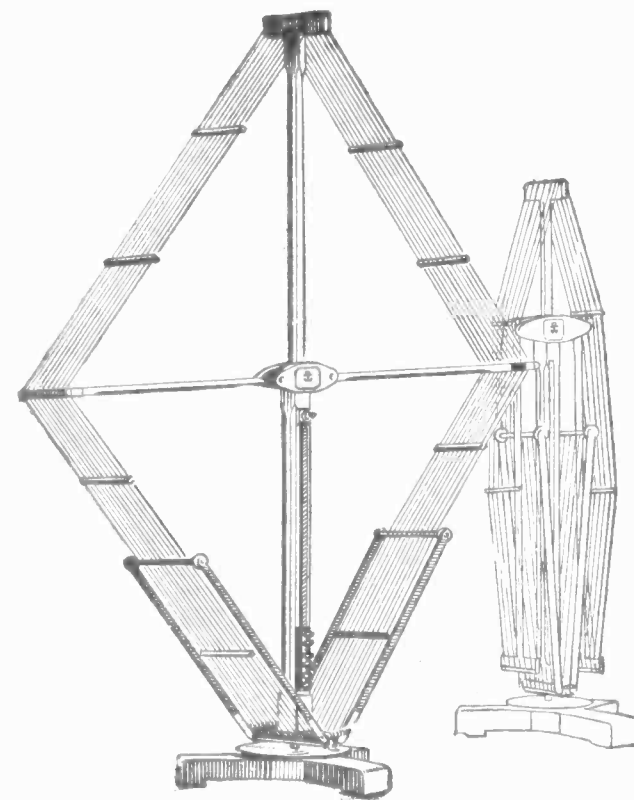

Price, \$25.00

CUT OUT

I am interested in the DTW loop advertised in RADIO PROGRESS.

Please send me literature descriptive of the loop.

(Name)

(Street)

(City) (State)

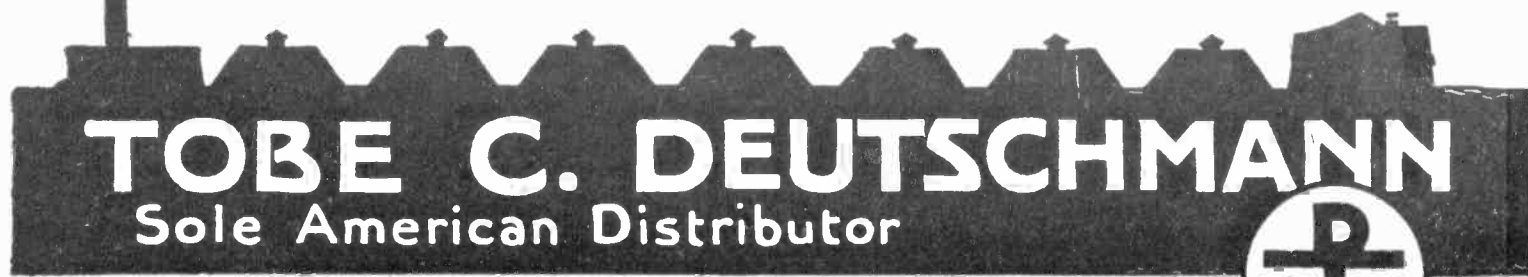

46 CORNHILL, BOSTON, MASS.



She Cut the Last Dance

It was the last regular dance of the season, too. At first he was desolated, but the thought then occurred to him that by adding a couple of steps of amplification to his single tube set he could get fox-trot music on his loud speaker. So he purchased two RADICLEAR kits, and although he was no expert, he hooked them up.

Presto! The music was so loud and clear that she consented to come to an informal dance and all was happy again.

Many transformers, while giving music almost as sweet as the RADICLEAR, are still not loud enough to permit dancing. It requires a large amount of engineering skill to combine sweetness of tone and loud volume in the same unit.

One of the things which helps accomplish this result is the kind of insulation used between layers in winding the secondary. This insulation has been especially developed for just such a purpose. So many transformer builders use ordinary insulation and so get very ordinary results.

The transformer alone sells for \$3.95, or the kit, which includes everything needed for a complete step of audio amplification, is \$6.00. This includes RADICLEAR transformer, rheostat, socket, (state kind of tube used), phone jack, amplifier, terminal, and wiring. Use the coupon for easy ordering.

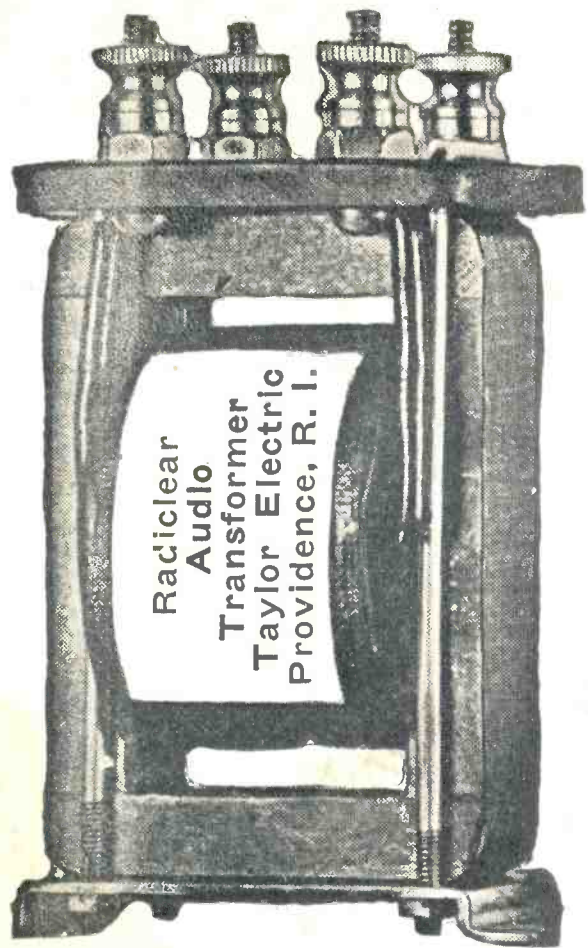

The Taylor Electric Company,
1206 Broad Street,
Providence, R. I.

Please send me the following by parcel post. (Mark which one you want.)
Radiclear Audio Transformer @ \$3.95
Amplifier set complete @\$6.00
(Socket to fit.....tube)
Audion Crystal @ 25c.
Gold Plated Cat Whisker @ 15c.

I enclose \$.... to pay for these.
(These above prices include the postage.)

Send them to me C. O. D. I will pay the above price plus postage.

(Indicate which way you wish to pay.)

Name.....

Address.....

TAYLOR ELECTRIC CO.

1206 Broad Street

Providence, R. I.